

FIRST STEPS IN TROPICAL INTERSECTION THEORY

LARS ALLERMANN AND JOHANNES RAU

ABSTRACT. We establish first parts of a tropical intersection theory. Namely, we define cycles, Cartier divisors and intersection products between these two (*without* passing to rational equivalence) and discuss push-forward and pull-back. We do this first for fans in \mathbb{R}^n and then for “abstract” cycles that are fans locally. With regard to applications in enumerative geometry, we finally have a look at rational equivalence and intersection products of cycles and cycle classes in \mathbb{R}^n .

1. INTRODUCTION

Tropical geometry is a recent development in the field of algebraic geometry that tries to transform algebro-geometric problems into easier, purely combinatorial ones. In the last few years various authors were able to answer questions of enumerative algebraic geometry using these techniques. In order to determine the number of (classical) curves meeting given conditions in some ambient space they constructed moduli spaces of tropical curves and had to intersect the corresponding tropical conditions in these moduli spaces. Since there is no tropical intersection theory yet the computation of the arising intersection multiplicities and the proof of the independence of the choice of the conditions had to be repeated for every single problem without the tools of an elaborated intersection theory (see for example [GM], [KM]).

A first draft of a general tropical intersection theory without proofs has been presented by Mikhalkin in [M]. The concepts introduced there — if set up rigorously — would help to unify and solve the above mentioned problems and would provide utilities for further applications. Thus in this paper we develop in detail the basics of a general tropical intersection theory based on Mikhalkin’s ideas.

This paper consists of three parts: In the first part (sections 2 - 4) we firstly introduce affine tropical cycles as balanced weighted fans modulo refinements and affine tropical varieties as affine cycles with non-negative weights. One would like to define the intersection of two such objects but in general neither is the set-theoretic intersection of two cycles again a cycle nor does the concept of stable intersection as introduced in [RGST] work for arbitrary ambient spaces as can be seen in example 3.10. Therefore we introduce the notion of affine Cartier divisors on tropical cycles as piecewise integer affine linear functions modulo globally affine linear functions and define a bilinear intersection product of Cartier divisors and cycles. We then prove the commutativity of this product and a projection formula for push-forwards of cycles and pull-backs of Cartier divisors. In the second part (sections 5 - 8) we generalize the theory developed in the first part to abstract cycles which are abstract polyhedral complexes modulo refinements with affine cycles as local building blocks. Again, abstract tropical varieties are just cycles with non-negative weights. In both the affine and abstract case a remarkable difference to the classical situation occurs: We

can define the mentioned intersection products on the level of cycles, i.e. we can intersect Cartier divisors with cycles and obtain a well-defined cycle — not only a cycle class up to rational equivalence as it is the case in classical algebraic geometry. However, for simplifying the computations of concrete enumerative numbers we introduce a notion of rational equivalence of cycles in section 8. In the third part (section 9) we finally use our theory to define the intersection product of two cycles with ambient space \mathbb{R}^n . Here again it is remarkable that we can define these intersections — even for self-intersections — on the level of cycles. We suppose this intersection product to be identical with the *stable intersection* discussed in [M] and [RGST] though we could not prove it yet.

There are three more articles related to our work that we want to mention: In [K] the author studies the relations between the intersection products of toric varieties and the tropical intersection product on \mathbb{R}^n in the case of transversal intersections. This article is closely related to [FS]: In this work the authors give a description of the Chow cohomology of a complete toric variety in terms of *Minkowski weights*. These objects — representing cocycles in the toric variety — are affine tropical cycles in \mathbb{R}^n according to our definition. Moreover, there is an intersection product of these Minkowski weights corresponding to the cup product of the associated cocycles that can be calculated via a *fan displacement rule*. This rule equals the stable intersection of tropical cycles in \mathbb{R}^n mentioned above for the case of affine cycles. But there are also discrepancies between these two interpretations of Minkowski weights: Morphisms of toric varieties as well as morphisms of affine tropical cycles are just given by integer linear maps. However, the requirements for the fans are quite different for both kinds of morphisms. Also the functorial behavior is totally different for both interpretations: Regarded as toric cocycles, Minkowski weights have pull-backs along morphisms, whereas interpreted as affine tropical cycles they admit push-forwards. In [ST] the authors study homomorphisms of tori and their induced morphisms of toric varieties and tropical varieties, respectively. Generically finite morphisms in this context are closely related to push-forwards of tropical cycles as defined in construction 4.2.

We would like to thank our advisor Andreas Gathmann for numerous helpful discussions and his inspiring ideas that made this paper possible.

2. AFFINE TROPICAL CYCLES

In this section we will briefly summarize the definitions and some properties of our basic objects. We refer to [GKM] for more details (but note that we use a slightly more general definition of fan).

In the following sections Λ will denote a finitely generated free abelian group, i.e. a group isomorphic to \mathbb{Z}^r for some $r \in \mathbb{N}$, and $V := \Lambda \otimes_{\mathbb{Z}} \mathbb{R}$ the associated real vector space containing Λ as a lattice. We will denote the dual lattice in the dual vector space by $\Lambda^\vee \subseteq V^\vee$.

Definition 2.1 (Cones). A *cone* in V is a subset $\sigma \subseteq V$ that can be described by finitely many linear integral equalities and inequalities, i.e. a set of the form

$$\sigma = \{x \in V \mid f_1(x) = 0, \dots, f_r(x) = 0, f_{r+1}(x) \geq 0, \dots, f_N(x) \geq 0\}$$

for some linear forms $f_1, \dots, f_N \in \Lambda^\vee$. We denote by V_σ the smallest linear subspace of V containing σ and by Λ_σ the lattice $V_\sigma \cap \Lambda$. We define the *dimension* of σ to be the dimension of V_σ .

Definition 2.2 (Fans). A *fan* X in V is a finite set of cones in V satisfying the following conditions:

- (a) The intersection of any two cones in X belongs to X as well,
- (b) every cone $\sigma \in X$ is the disjoint union $\sigma = \dot{\bigcup}_{\tau \in X: \tau \subseteq \sigma} \tau^{ri}$, where τ^{ri} denotes the relative interior of τ , i.e. the interior of τ in V_τ .

We will denote the set of all k -dimensional cones of X by $X^{(k)}$. The *dimension* of X is defined to be the maximum of the dimensions of the cones in X . The fan X is called *pure-dimensional* if each inclusion-maximal cone in X has this dimension. The union of all cones in X will be denoted $|X| \subseteq V$. If X is a fan of pure dimension k then the cones $\sigma \in X^{(k)}$ are called *facets* of X .

Let X be a fan and $\sigma \in X$ a cone. A cone $\tau \in X$ with $\tau \subseteq \sigma$ is called a *face* of σ . We write this as $\tau \leq \sigma$ (or $\tau < \sigma$ if in addition $\tau \subsetneq \sigma$ holds). Clearly we have $V_\tau \subseteq V_\sigma$ and $\Lambda_\tau \subseteq \Lambda_\sigma$ in this case. Note that $\tau < \sigma$ implies that τ is contained in a proper face (in the usual sense) of σ .

Construction 2.3 (Normal vectors). Let $\tau < \sigma$ be cones of some fan X in V with $\dim(\tau) = \dim(\sigma) - 1$. This implies that there is a linear form $f \in \Lambda_\sigma^\vee$ that is zero on τ , non-negative on σ and not identically zero on σ . Let $u_\sigma \in \Lambda_\sigma$ be a vector generating $\Lambda_\sigma/\Lambda_\tau \cong \mathbb{Z}$ with $f(u_\sigma) > 0$. Note that its class $u_{\sigma/\tau} := [u_\sigma] \in \Lambda_\sigma/\Lambda_\tau$ does not depend on the choice of u_σ . We call $u_{\sigma/\tau}$ the (*primitive*) *normal vector* of σ relative to τ .

Definition 2.4 (Subfans). Let X, Y be fans in V . Y is called a *subfan* of X if for every cone $\sigma \in Y$ there exists a cone $\sigma' \in X$ such that $\sigma \subseteq \sigma'$. In this case we write $Y \triangleleft X$ and define a map $C_{Y,X} : Y \rightarrow X$ that maps a cone $\sigma \in Y$ to the unique inclusion-minimal cone $\sigma' \in X$ with $\sigma \subseteq \sigma'$.

Definition 2.5 (Weighted fans). A *weighted fan* (X, ω_X) of dimension k in V is a fan X in V of pure dimension k , together with a map $\omega_X : X^{(k)} \rightarrow \mathbb{Z}$. The number $\omega_X(\sigma)$ is called the *weight* of the facet $\sigma \in X^{(k)}$. For simplicity we usually write $\omega(\sigma)$ instead of $\omega_X(\sigma)$. Moreover, we want to consider the *empty fan* \emptyset to be a weighted fan of dimension k for all k . Furthermore, by abuse of notation we simply write X for the weighted fan (X, ω_X) if the weight function ω_X is clear from the context.

Definition 2.6 (Tropical fans). A *tropical fan* of dimension k in V is a weighted fan (X, ω_X) of dimension k satisfying the following *balancing condition* for every $\tau \in X^{(k-1)}$:

$$\sum_{\sigma: \tau < \sigma} \omega_X(\sigma) \cdot u_{\sigma/\tau} = 0 \in V/V_\tau.$$

Let (X, ω_X) be a weighted fan of dimension k in V and X^* the fan

$$X^* := \{\tau \in X \mid \tau \leq \sigma \text{ for some facet } \sigma \in X \text{ with } \omega_X(\sigma) \neq 0\}.$$

$(X^*, \omega_{X^*}) := (X^*, \omega_X|_{(X^*)^{(k)}})$ is called the *non-zero part* of X and is again a weighted fan of dimension k in V (note that $X^* = \emptyset$ is possible). Obviously (X^*, ω_{X^*}) is a tropical fan if and only if (X, ω_X) is one. We call a weighted fan (X, ω_X) *reduced* if all its facets have non-zero weight, i.e. if $(X, \omega_X) = (X^*, \omega_{X^*})$ holds.

Remark 2.7. Let (X, ω_X) be a tropical fan of dimension k and let $\tau \in X^{(k-1)}$. Let $\sigma_1, \dots, \sigma_N$ be all cones in X with $\sigma_i > \tau$. For all i let $v_{\sigma_i/\tau} \in \Lambda$ be a representative of the primitive normal vector $u_{\sigma_i/\tau} \in \Lambda/\Lambda_\tau$. By the above balancing condition

we have $\sum_{i=1}^N \omega_X(\sigma_i) \cdot v_{\sigma_i/\tau} = \lambda_\tau$ for some $\lambda_\tau \in \Lambda_\tau$. Obviously we have $\lambda_\tau = \gcd(\omega_X(\sigma_1), \dots, \omega_X(\sigma_N)) \cdot \tilde{\lambda}_\tau$ for some further $\tilde{\lambda}_\tau \in \Lambda_\tau$. We can represent the greatest common divisor by a linear combination $\gcd(\omega_X(\sigma_1), \dots, \omega_X(\sigma_N)) = \alpha_1 \omega_X(\sigma_1) + \dots + \alpha_N \omega_X(\sigma_N)$ with $\alpha_1, \dots, \alpha_N \in \mathbb{Z}$ and define

$$\tilde{v}_{\sigma_i/\tau} := v_{\sigma_i/\tau} - \alpha_i \cdot \tilde{\lambda}_\tau$$

for all i . Note that $\tilde{v}_{\sigma_i/\tau}$ is a representative of $u_{\sigma_i/\tau}$, too. Replacing all $v_{\sigma_i/\tau}$ by $\tilde{v}_{\sigma_i/\tau}$ we can always assume that $\sum_{i=1}^N \omega_X(\sigma_i) \cdot v_{\sigma_i/\tau} = 0 \in \Lambda$.

Definition 2.8 (Refinements). Let (X, ω_X) and (Y, ω_Y) be weighted fans in V . We call (Y, ω_Y) a *refinement* of (X, ω_X) if the following holds:

- (a) $Y^* \trianglelefteq X^*$,
- (b) $|Y^*| = |X^*|$ and
- (c) $\omega_Y(\sigma) = \omega_X(C_{Y^*, X^*}(\sigma))$ for every $\sigma \in (Y^*)^{(\dim(Y))}$.

Note that property (b) implies that either $X^* = Y^* = \emptyset$ or $\dim(X) = \dim(Y)$. We call two weighted fans (X, ω_X) and (Y, ω_Y) in V *equivalent* (write $(X, \omega_X) \sim (Y, \omega_Y)$) if they have a common refinement. Note that (X, ω_X) and $(X^*, \omega_X|_{(X^*)^{(\dim(X))}})$ are always equivalent.

Remark 2.9. Note that for a weighted fan (X, ω_X) of dimension k and a refinement (Y, ω_Y) we have the following two properties:

- (a) $|X^*| = |Y^*|$, i.e. the support $|X^*|$ is well-defined on the equivalence class of X ,
- (b) for every cone $\tau \in Y^{(k-1)}$ there are exactly two cases that can occur: Either $\dim C_{Y, X}(\tau) = k$ or $\dim C_{Y, X}(\tau) = k - 1$. In the first case all cones $\sigma \in Y^{(k)}$ with $\sigma > \tau$ must be contained in $C_{Y, X}(\tau)$. Thus there are precisely two such cones σ_1 and σ_2 with $\omega_Y(\sigma_1) = \omega_Y(\sigma_2)$ and $u_{\sigma_1/\tau} = -u_{\sigma_2/\tau}$. In the second case we have a 1:1 correspondence between cones $\sigma \in Y^{(k)}$ with $\tau < \sigma$ and cones $\sigma' \in X^{(k)}$ with $C_{Y, X}(\tau) < \sigma'$ preserving weights and normal vectors.

Construction 2.10 (Refinements). Let (X, ω_X) be a weighted fan and Y be any fan in V with $|X| \subseteq |Y|$. Let $P := \{\sigma \cap \sigma' \mid \sigma \in X, \sigma' \in Y\}$. In general P is not a fan in V as can be seen in the following example:

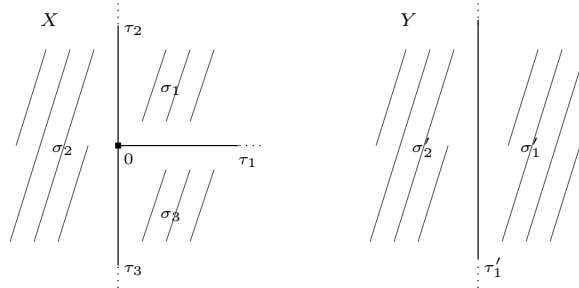

Fans X and Y such that $\{\sigma \cap \sigma' \mid \sigma \in X, \sigma' \in Y\}$ is not a fan.

Here P contains $\tau'_1 = \sigma_2 \cap \sigma'_1$, but also $\tau_2 = \sigma_1 \cap \sigma'_2$ and $\tau_3 = \sigma_3 \cap \sigma'_2$. Hence property (b) of definition 2.2 is not fulfilled. To resolve this, we define

$$X \cap Y := \{\sigma \in P \mid \nexists \tau \in P^{(\dim(\sigma))} \text{ with } \tau \subsetneq \sigma\}.$$

Note that $X \cap Y$ is now a fan in V . We can make it into a weighted fan by setting $\omega_{X \cap Y}(\sigma) := \omega_X(C_{X \cap Y, X}(\sigma))$ for all $\sigma \in (X \cap Y)^{(\dim(X))}$. Then $(X \cap Y, \omega_{X \cap Y})$ is a refinement of (X, ω_X) . Note that if (X, ω_X) and (Y, ω_Y) are both weighted fans and $|X| = |Y|$ we can form both intersections $X \cap Y$ and $Y \cap X$. Of course, the underlying fans are the same in both cases, but the weights may differ since they are always induced by the first complex.

The following setting is a special case of this construction: Let (X, ω_X) be a weighted fan of dimension k in V and let $f \in \Lambda^\vee$ be a non-zero linear form. Then we can construct a refinement of (X, ω_X) as follows:

$$H_f := \{\{x \in V | f(x) \leq 0\}, \{x \in V | f(x) = 0\}, \{x \in V | f(x) \geq 0\}\}$$

is a fan in V with $|H_f| = V$. Thus we have $|X| \subseteq |H_f|$ and by our above construction we get a refinement $(X_f, \omega_{X_f}) := (X \cap H_f, \omega_{X \cap H_f})$ of X .

Obviously we still have to answer the question if the equivalence of weighted fans is indeed an equivalence relation and if this notion of equivalence is well-defined on tropical fans. We will do this in the following lemma:

Lemma 2.11.

- (a) *The relation “ \sim ” is an equivalence relation on the set of k -dimensional weighted fans in V .*
- (b) *If (X, ω_X) is a weighted fan of dimension k and (Y, ω_Y) is a refinement then (X, ω_X) is a tropical fan if and only if (Y, ω_Y) is one.*

Proof. Recall that a fan and its non-zero part are always equivalent and that a weighted fan X is tropical if and only if its non-zero part X^* is. Thus we may assume that all our fans are reduced and the proof is the same as in [GKM, section 2]. \square

Having done all these preparations we are now able to introduce the most important objects for the succeeding sections:

Definition 2.12 (Affine cycles and affine tropical varieties). Let (X, ω_X) be a tropical fan of dimension k in V . We denote by $[(X, \omega_X)]$ its equivalence class under the equivalence relation “ \sim ” and by $Z_k^{\text{aff}}(V)$ the set of equivalence classes

$$Z_k^{\text{aff}}(V) := \{[(X, \omega_X)] | (X, \omega_X) \text{ tropical fan of dimension } k \text{ in } V\}.$$

The elements of $Z_k^{\text{aff}}(V)$ are called *affine (tropical) k -cycles* in V . A k -cycle $[(X, \omega_X)]$ is called an *affine tropical variety* if $\omega_X(\sigma) \geq 0$ for every $\sigma \in X^{(k)}$. Note that the last property is independent of the choice of the representative of $[(X, \omega_X)]$. Moreover, note that $0 := [\emptyset] \in Z_k^{\text{aff}}(V)$ for every k . We define $[[X, \omega_X]] := |X^*|$. This definition is well-defined by remark 2.9.

Construction 2.13 (Sums of affine cycles). Let $[(X, \omega_X)]$ and $[(Y, \omega_Y)]$ be k -cycles in V . We would like to form a fan $X + Y$ by taking the union $X \cup Y$, but obviously this collection of cones is in general not a fan. Using appropriate refinements we can resolve this problem: Let $f_1(x) \geq 0, \dots, f_{N_1}(x) \geq 0, f_{N_1+1}(x) = 0, \dots, f_N(x) = 0$ and $g_1(x) \geq 0, \dots, g_{M_1}(x) \geq 0, g_{M_1+1}(x) = 0, \dots, g_M(x) = 0$ be all different equalities and inequalities occurring in the descriptions of all the cones belonging to X and Y respectively. Using construction 2.10 we get refinements

$$\tilde{X} := X \cap H_{f_1} \cap \dots \cap H_{f_N} \cap H_{g_1} \cap \dots \cap H_{g_M}$$

of X and

$$\tilde{Y} := Y \cap H_{f_1} \cap \cdots \cap H_{f_N} \cap H_{g_1} \cap \cdots \cap H_{g_M}$$

of Y (note that the final refinements do not depend on the order of the single refinements). A cone occurring in \tilde{X} or \tilde{Y} is then of the form

$$\sigma = \left\{ \begin{array}{l} f_i(x) \leq 0, \quad f_j(x) = 0, \quad f_k(x) \geq 0, \\ g_{i'}(x) \leq 0, \quad g_{j'}(x) = 0, \quad g_{k'}(x) \geq 0 \end{array} \middle| \begin{array}{l} i \in I, \quad j \in J, \quad k \in K, \\ i' \in I', \quad j' \in J', \quad k' \in K' \end{array} \right\}$$

for some partitions $I \cup J \cup K = \{1, \dots, N\}$ and $I' \cup J' \cup K' = \{1, \dots, M\}$. Now, all these cones σ belong to the fan $H_{f_1} \cap \cdots \cap H_{f_N} \cap H_{g_1} \cap \cdots \cap H_{g_M}$ as well and hence $\tilde{X} \cup \tilde{Y}$ fulfills definition 2.2. Thus, now we can define the *sum of X and Y* to be $X + Y := \tilde{X} \cup \tilde{Y}$ together with weights $\omega_{X+Y}(\sigma) := \omega_{\tilde{X}}(\sigma) + \omega_{\tilde{Y}}(\sigma)$ for every facet of $X + Y$ (we set $\omega_{\square}(\sigma) := 0$ if σ does not occur in $\square \in \{\tilde{X}, \tilde{Y}\}$). By construction, $(X + Y, \omega_{X+Y})$ is again a tropical fan of dimension k . Moreover, enlarging the sets $\{f_i\}, \{g_j\}$ by more (in)equalities just corresponds to refinements of X and Y and only leads to a refinement of $X + Y$. Thus, replacing the set of relations by another one that also describes the cones in X and Y , or replacing X or Y by refinements keeps the equivalence class $[(X + Y, \omega_{X+Y})]$ unchanged, i.e. taking sums is a well-defined operation on cycles.

This construction immediately leads to the following lemma:

Lemma 2.14. $Z_k^{\text{aff}}(V)$ together with the operation “+” from construction 2.13 forms an abelian group.

Proof. The class of the empty fan $0 = [\emptyset]$ is the neutral element of this operation and $[(X, -\omega_X)]$ is the inverse element of $[(X, \omega_X)] \in Z_k^{\text{aff}}(V)$. \square

Of course we do not want to restrict ourselves to cycles situated in some \mathbb{R}^n . Therefore we give the following generalization of definition 2.12:

Definition 2.15. Let X be a fan in V . An *affine k -cycle in X* is an element $[(Y, \omega_Y)]$ of $Z_k^{\text{aff}}(V)$ such that $|Y^*| \subseteq |X|$. We denote by $Z_k^{\text{aff}}(X)$ the set of k -cycles in X . Note that $(Z_k^{\text{aff}}(X), +)$ is a subgroup of $(Z_k^{\text{aff}}(V), +)$. The elements of the group $Z_{\dim X - 1}^{\text{aff}}(X)$ are called *Weil divisors on X* . If $[(X, \omega_X)]$ is a cycle in V then $Z_k^{\text{aff}}([(X, \omega_X)]) := Z_k^{\text{aff}}(X^*)$.

3. AFFINE CARTIER DIVISORS AND THEIR ASSOCIATED WEIL DIVISORS

Definition 3.1 (Rational functions). Let C be an affine k -cycle. A *(non-zero) rational function on C* is a continuous piecewise linear function $\varphi : |C| \rightarrow \mathbb{R}$, i.e. there exists a representative (X, ω_X) of C such that on each cone $\sigma \in X$, φ is the restriction of an integer affine linear function $\varphi|_{\sigma} = \lambda + c$, $\lambda \in \Lambda_{\sigma}^{\vee}$, $c \in \mathbb{R}$. Obviously, c is the same on all faces by $c = \varphi(0)$ and λ is uniquely determined by φ and therefore denoted by $\varphi_{\sigma} := \lambda$. The set of *(non-zero) rational functions of C* is denoted by $\mathcal{K}^*(C)$.

Remark 3.2 (The zero function and restrictions to subcycles). The “zero” function can be thought of being the constant function $-\infty$, therefore $\mathcal{K}(C) := \mathcal{K}^*(C) \cup \{-\infty\}$. With respect to the operations \max and $+$, $\mathcal{K}(C)$ is a semifield.

Let us note an important difference to the classical case: Let D be an arbitrary subcycle of C and $\varphi \in \mathcal{K}^*(C)$. Then $\varphi|_{|D|} \in \mathcal{K}^*(D)$, whereas in the classical case it might become zero. This will be crucial for defining intersection products not only modulo rational equivalence. On the other hand, the definition of rational functions given above, requiring the

function to be defined everywhere, seems to be restrictive when compared to the classical case, even so “being defined” does not imply “being regular” tropically. In some cases (see remark 8.6) it would be desirable to generalize our definition while preserving the above restriction property.

As in the classical case, each non-zero rational function φ on C defines a Weil divisor, i.e. a cycle in $Z_{\dim C - 1}^{\text{aff}}(C)$. The idea of course should be to describe the “zeros” and “poles” of φ . A naive approach could be to consider the graph of φ in $V \times \mathbb{R}$ and “intersect it with $V \times \{-\infty\}$ and $V \times \{+\infty\}$ ”. However, our function φ takes values only in \mathbb{R} , in fact. On the other hand, the graph of φ is not a tropical object as it is not balanced: Where φ is not linear, our graph gets edges that might violate the balancing condition. So, we first make the graph balanced by adding new faces in the additional direction $(0, -1) \in V \times \mathbb{R}$ and then apply our naive approach. Let us make this precise.

Construction 3.3 (The associated Weil divisor). Let C be an affine k -cycle in $V = \Lambda \otimes \mathbb{R}$ and $\varphi \in \mathcal{K}^*(C)$ a rational function on C . Let furthermore (X, ω) be a representative of C on whose faces φ is affine linear. Therefore, for each cone $\sigma \in X$, we get a cone $\tilde{\sigma} := (\text{id} \times \varphi_\sigma)(\sigma)$ in $V \times \mathbb{R}$ of the same dimension. Obviously, $\Gamma_\varphi := \{\tilde{\sigma} \mid \sigma \in X\}$ forms a fan which we can make into a weighted fan $(\Gamma_\varphi, \tilde{\omega})$ by $\tilde{\omega}(\tilde{\sigma}) := \omega(\sigma)$. Its support is just the set-theoretic graph of $\varphi - \varphi(0)$ in $|X| \times \mathbb{R}$.

For $\tau < \sigma$ with $\dim(\tau) = \dim(\sigma) - 1$ let $v_{\sigma/\tau} \in \Lambda$ be a representative of the normal vector $u_{\sigma/\tau}$. Then, $(v_{\sigma/\tau}, \varphi_\sigma(v_{\sigma/\tau})) \in \Lambda \times \mathbb{Z}$ is a representative of the normal vector $u_{\tilde{\sigma}/\tilde{\tau}}$. Therefore, summing around a cone $\tilde{\tau}$ with $\dim \tilde{\tau} = \dim \tau = k - 1$, we get

$$\sum_{\substack{\tilde{\sigma} \in \Gamma_\varphi^{(k)} \\ \tilde{\tau} < \tilde{\sigma}}} \tilde{\omega}(\tilde{\sigma}) (v_{\sigma/\tau}, \varphi_\sigma(v_{\sigma/\tau})) = \left(\sum_{\substack{\sigma \in X^{(k)} \\ \tau < \sigma}} \omega(\sigma) v_{\sigma/\tau}, \sum_{\substack{\sigma \in X^{(k)} \\ \tau < \sigma}} \varphi_\sigma(\omega(\sigma) v_{\sigma/\tau}) \right).$$

From the balancing condition for (X, ω) it follows that $\sum_{\sigma \in X^{(k)}: \tau < \sigma} \omega(\sigma) v_{\sigma/\tau} \in V_\tau$, which also means $(\sum_{\sigma \in X^{(k)}: \tau < \sigma} \omega(\sigma) v_{\sigma/\tau}, \varphi_\tau(\sum_{\sigma \in X^{(k)}: \tau < \sigma} \omega(\sigma) v_{\sigma/\tau})) \in V_{\tilde{\tau}}$. Therefore, modulo $V_{\tilde{\tau}}$, our first sum equals

$$\left(0, \sum_{\substack{\sigma \in X^{(k)} \\ \tau < \sigma}} \varphi_\sigma(\omega(\sigma) v_{\sigma/\tau}) - \varphi_\tau \left(\sum_{\substack{\sigma \in X^{(k)} \\ \tau < \sigma}} \omega(\sigma) v_{\sigma/\tau} \right) \right) \in V \times \mathbb{R}.$$

So, in order to “make $(\Gamma_\varphi, \tilde{\omega})$ balanced at $\tilde{\tau}$ ”, we add the cone $\vartheta := \tilde{\tau} + (\{0\} \times \mathbb{R}_{\leq 0})$ with weight $\tilde{\omega}(\vartheta) = \sum_{\sigma \in X^{(k)}: \tau < \sigma} \varphi_\sigma(\omega(\sigma) v_{\sigma/\tau}) - \varphi_\tau(\sum_{\sigma \in X^{(k)}: \tau < \sigma} \omega(\sigma) v_{\sigma/\tau})$. As obviously $[(0, -1)] = u_{\vartheta/\tilde{\tau}} \in (V \times \mathbb{R})/V_{\tilde{\tau}}$, the above calculation shows that then the balancing condition around $\tilde{\tau}$ holds. In other words, we build the new fan $(\Gamma'_\varphi, \tilde{\omega}')$, where

$$\begin{aligned} \Gamma'_\varphi &:= \Gamma_\varphi \cup \left\{ \tilde{\tau} + (\{0\} \times \mathbb{R}_{\leq 0}) \mid \tilde{\tau} \in \Gamma_\varphi \setminus \Gamma_\varphi^{(k)} \right\}, \\ \tilde{\omega}'|_{\Gamma_\varphi^{(k)}} &:= \tilde{\omega}, \\ \tilde{\omega}'(\tilde{\tau} + (\{0\} \times \mathbb{R}_{\leq 0})) &:= \sum_{\substack{\sigma \in X^{(k)} \\ \tau < \sigma}} \varphi_\sigma(\omega(\sigma) v_{\sigma/\tau}) - \varphi_\tau \left(\sum_{\substack{\sigma \in X^{(k)} \\ \tau < \sigma}} \omega(\sigma) v_{\sigma/\tau} \right) \\ &\quad \text{if } \dim \tilde{\tau} = k - 1. \end{aligned}$$

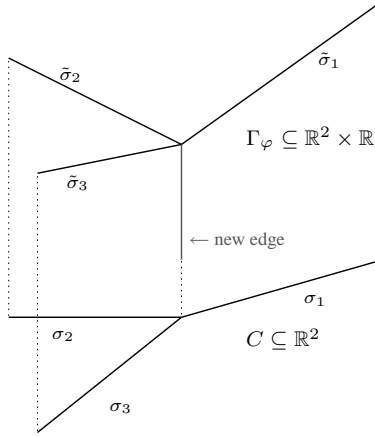

Construction of a Weil divisor.

This fan is balanced around all $\tilde{\tau} \in \Gamma_\varphi^{(k-1)}$. We will show that it is also balanced at all “new” cones of dimension $k - 1$ in proposition 3.7.

We now think of intersecting this new fan with $V \times \{-\infty\}$ to get our desired Weil divisor (As our weights are allowed to be negative, we can forget about intersecting also with $V \times \{+\infty\}$). This construction leads to the following definition.

Definition 3.4 (Associated Weil divisors). Let C be an affine k -cycle in $V = \Lambda \otimes \mathbb{R}$ and $\varphi \in \mathcal{K}^*(C)$ a rational function on C . Let furthermore (X, ω) be a representative of C on whose cones φ is affine linear. We define $\text{div}(\varphi) := \varphi \cdot C := [(\bigcup_{i=0}^{k-1} X^{(i)}, \omega_\varphi)] \in Z_{k-1}^{\text{aff}}(C)$, where

$$\begin{aligned} \omega_\varphi : X^{(k-1)} &\rightarrow \mathbb{Z}, \\ \tau &\mapsto \sum_{\substack{\sigma \in X^{(k)} \\ \tilde{\tau} < \sigma}} \varphi_\sigma(\omega(\sigma)v_{\sigma/\tau}) - \varphi_\tau \left(\sum_{\substack{\sigma \in X^{(k)} \\ \tilde{\tau} < \sigma}} \omega(\sigma)v_{\sigma/\tau} \right) \end{aligned}$$

and the $v_{\sigma/\tau}$ are arbitrary representatives of the normal vectors $u_{\sigma/\tau}$.

Let D be an arbitrary subcycle of C . By remark 3.2, we can define $\varphi \cdot D := \varphi|_{|D|} \cdot D$.

Remark 3.5. Obviously, $\omega_\varphi(\tau)$ is independent of the choice of the $v_{\sigma/\tau}$, as a different choice only differs by elements in V_τ .

Our definition does also not depend on the choice of a representative (X, ω) : Let (Y, ν) be a refinement of (X, ω) . For $\tau \in Y^{(k-1)}$, two cases can occur (see also remark 2.9): Let $\tau' := C_{Y,X}(\tau)$. If $\dim \tau' = k$, there are precisely two cones at $\tau < \sigma_1, \sigma_2 \in Y^{(k)}$, which then fulfill $C_{Y,X}(\sigma_1) = C_{Y,X}(\sigma_2)$ and therefore $u_{\sigma_1/\tau} = -u_{\sigma_2/\tau}$, $v(\sigma_1) = v(\sigma_2)$ and $\varphi_{\sigma_1} = \varphi_{\sigma_2}$. It follows that $v_\varphi(\tau) = 0$. If $\dim \tau' = k - 1$, $C_{Y,X}$ gives a one-to-one correspondence between $\{\sigma \in Y^{(k)} | \tau < \sigma\}$ and $\{\sigma' \in X^{(k)} | \tau' < \sigma'\}$ respecting weights and normal vectors, and we have $\varphi_\sigma = \varphi_{C_{Y,X}(\sigma)}$. It follows that $v_\varphi(\tau) = \omega_\varphi(\tau')$. So the two weighted fans we obtain are equivalent.

Remark 3.6 (Affine linear functions and sums). Let $\varphi \in \mathcal{K}^*(C)$ be globally affine linear, i.e. $\varphi = \lambda|_{|C|} + c$ for some $\lambda \in \Lambda^\vee$, $c \in \mathbb{R}$. Then obviously $\varphi \cdot C = 0$.

Let furthermore $\psi \in \mathcal{K}^*(C)$ be another rational function on C . From $\varphi_\sigma + \psi_\sigma = (\varphi + \psi)_\sigma$ it follows that $(\varphi + \psi) \cdot C = \varphi \cdot C + \psi \cdot C$.

Proposition 3.7 (Balancing Condition and Commutativity).

- (a) Let C be an affine k -cycle in $V = \Lambda \otimes \mathbb{R}$ and $\varphi \in \mathcal{K}^*(C)$ a rational function on C . Then $\text{div}(\varphi) = \varphi \cdot C$ is an equivalence class of tropical fans, i.e. its representatives are balanced.
- (b) Let $\psi \in \mathcal{K}^*(C)$ be another rational function on C . Then it holds $\psi \cdot (\varphi \cdot C) = \varphi \cdot (\psi \cdot C)$.

Proof. (a): Let (X, ω) be a representative of C on whose cones φ is affine linear. Pick a $\theta \in X^{(k-2)}$. We choose an element $\lambda \in \Lambda^\vee$ with $\lambda|_{V_\theta} = \varphi_\theta$. By remark 3.6, we can go on with $\varphi - \lambda - \varphi(0) \in \mathcal{K}^*(C)$ instead of φ . By dividing out V_θ , we can restrict ourselves to the situation $\dim X = 2$, $\theta = \{0\}$.

By a further refinement (i.e. by cutting an possibly occuring halfspace into two pieces along an additional ray), we can assume that all cones $\sigma \in X$ are simplicial. Therefore each two-dimensional cone $\sigma \in X^{(2)}$ is generated by two unique rays $\tau, \tau' \in X^{(1)}$, i.e. $\sigma = \tau + \tau'$. We denote

$$\chi(\sigma) := [\Lambda_\sigma : \Lambda_\tau + \Lambda_{\tau'}] = [\Lambda_\sigma : \mathbb{Z}u_{\tau/\{0\}} + \mathbb{Z}u_{\tau'/\{0\}}],$$

where $u_{\tau/\{0\}}$ and $u_{\tau'/\{0\}}$ denote the primitive normal vectors introduced in construction 2.3. Then we get

$$[u_{\tau'/\{0\}}] = \chi(\sigma)u_{\sigma/\tau} \pmod{V_\tau}.$$

This equation can be shown for example as follows: The linear extension of the following function

$$\begin{aligned} \text{index} : \Lambda_\sigma \setminus \Lambda_\tau &\rightarrow \mathbb{Z}, \\ v &\mapsto [\Lambda_\sigma : \mathbb{Z}u_{\tau/\{0\}} + \mathbb{Z}v] \end{aligned}$$

to Λ_σ is in fact trivial on Λ_τ . Therefore it can also be considered as a function on $\Lambda_\sigma/\Lambda_\tau$. But by definitions we know $\text{index}(u_{\sigma/\tau}) = 1$ (as $u_{\tau/\{0\}}$ and any representative of $u_{\sigma/\tau}$ form a lattice basis of Λ_σ) and $\text{index}(u_{\tau'/\{0\}}) = \chi(\sigma)$, which proves the claim.

This means that we can rewrite the balancing condition of X around $\tau \in X^{(1)}$ only using the vectors generating the rays, namely

$$\begin{aligned} \sum_{\substack{\tau' \in X^{(1)} \\ \tau + \tau' \in X^{(2)}}} \frac{\omega(\sigma)}{\chi(\sigma)} u_{\tau'/\{0\}} &\in V_\tau \\ &= \lambda_\tau u_{\tau/\{0\}}, \end{aligned}$$

where λ_τ is a coefficient in \mathbb{R} and σ denotes $\tau + \tau'$ in such sums. Of course, we can also compute the weight $\omega_\varphi(\tau)$ of τ in $\text{div}(\varphi)$:

$$\omega_\varphi(\tau) = \left(\sum_{\substack{\tau' \in X^{(1)} \\ \tau + \tau' \in X^{(2)}}} \frac{\omega(\sigma)}{\chi(\sigma)} \varphi(u_{\tau'/\{0\}}) \right) - \lambda_\tau \varphi(u_{\tau/\{0\}})$$

Let us now check the balancing condition of $\varphi \cdot C$ around $\{0\}$ by plugging in these equations. We get

$$\begin{aligned} \sum_{\tau \in X^{(1)}} \omega_\varphi(\tau) u_{\tau/\{0\}} &= \sum_{\substack{\tau, \tau' \in X^{(1)} \\ \tau + \tau' \in X^{(2)}}} \frac{\omega(\sigma)}{\chi(\sigma)} \varphi(u_{\tau'/\{0\}}) u_{\tau/\{0\}} \\ &\quad - \sum_{\tau \in X^{(1)}} \lambda_\tau \varphi(u_{\tau/\{0\}}) u_{\tau/\{0\}}. \end{aligned}$$

By Commuting τ and τ' in the first summand we get

$$\begin{aligned} \sum_{\tau \in X^{(1)}} \omega_\varphi(\tau) u_{\tau/\{0\}} &= \sum_{\substack{\tau, \tau' \in X^{(1)} \\ \tau + \tau' \in X^{(2)}}} \frac{\omega(\sigma)}{\chi(\sigma)} \varphi(u_{\tau/\{0\}}) u_{\tau'/\{0\}} \\ &\quad - \sum_{\tau \in X^{(1)}} \lambda_\tau \varphi(u_{\tau/\{0\}}) u_{\tau/\{0\}} \\ &= \sum_{\tau \in X^{(1)}} \varphi(u_{\tau/\{0\}}) \underbrace{\left(\left(\sum_{\substack{\tau' \in X^{(1)} \\ \tau + \tau' \in X^{(2)}}} \frac{\omega(\sigma)}{\chi(\sigma)} u_{\tau'/\{0\}} \right) - \lambda_\tau u_{\tau/\{0\}} \right)}_{=0 \text{ (balancing condition around } \tau)} \\ &= 0. \end{aligned}$$

This finishes the proof of (a).

(b): Let (X, ω) be a representative of C on whose cones φ and ψ are affine linear. Pick a $\theta \in X^{(k-2)}$. By the same reduction steps as in case (a), we can again restrict ourselves to $\dim X = 2$, $\theta = \{0\}$. With the notations and trick as in (a) we get

$$\omega_{\varphi, \psi}(\{0\}) = \sum_{\substack{\tau, \tau' \in X^{(1)} \\ \tau + \tau' \in X^{(2)}}} \frac{\omega(\sigma)}{\chi(\sigma)} \varphi(u_{\tau'/\{0\}}) \psi(u_{\tau/\{0\}}) = \omega_{\psi, \varphi}(\{0\}),$$

which finishes part (b). \square

Definition 3.8 (Affine Cartier divisors). Let C be an affine k -cycle. The subgroup of globally affine linear functions in $\mathcal{K}^*(C)$ with respect to $+$ is denoted by $\mathcal{O}^*(C)$. We define the *group of affine Cartier divisors* of C to be the quotient group $\text{Div}(C) := \mathcal{K}^*(C)/\mathcal{O}^*(C)$. Let $[\varphi] \in \text{Div}(C)$ be a Cartier divisor. By remark 3.6, the associated Weil divisor $\text{div}([\varphi]) := \text{div}(\varphi)$ is well-defined. We therefore get a bilinear mapping

$$\begin{aligned} \cdot : \text{Div}(C) \times Z_k^{\text{aff}}(C) &\rightarrow Z_{k-1}^{\text{aff}}(C), \\ ([\varphi], D) &\mapsto [\varphi] \cdot D = \varphi \cdot D, \end{aligned}$$

called *affine intersection product*.

Example 3.9 (Self-intersection of hyperplanes). Let $\Lambda = \mathbb{Z}^n$ (and thus $V = \mathbb{R}^n$), let e_1, \dots, e_n be the standard basis vectors in \mathbb{Z}^n and $e_0 := -e_1 - \dots - e_n$. By abuse of notation our ambient cycle is $\mathbb{R}^n := [(\{\mathbb{R}^n\}, \omega(\mathbb{R}^n) = 1)]$. Let us consider the ‘‘linear tropical polynomial’’ $h = x_1 \oplus \dots \oplus x_n \oplus 0 = \max\{x_1, \dots, x_n, 0\} : \mathbb{R}^n \rightarrow \mathbb{R}$. Obviously, h is a rational function in the sense of definition 3.1: For each subset $I \subsetneq \{0, 1, \dots, n\}$ we

denote by σ_I the simplicial cone of dimension $|I|$ generated by the vectors $-e_i$ for $i \in I$. Then h is integer linear on all σ_I , namely

$$h|_{\sigma_I}(x_1, \dots, x_n) = \begin{cases} 0 & \text{if } 0 \notin I, \\ x_i & \text{if there exists an } i \in \{1, \dots, n\} \setminus I. \end{cases}$$

Let L_k^n be the k -dimensional fan consisting of all cones σ_I with $|I| \leq k$ and weighted with the trivial weight function $\omega_{L_k^n}$. Then L_n^n is a representative of \mathbb{R}^n fulfilling the conditions of definition 3.1. We want to show

$$\underbrace{h \cdots h}_{k \text{ times}} \cdot \mathbb{R}^n = [L_{n-k}^n]. \quad (*)$$

This follows inductively from $h \cdot [L_{k+1}^n] = [L_k^n]$, so it remains to compute $\omega_{L_{k+1}^n, h}(\sigma_I)$ for all I with $|I| = k < n$. Let $J := \{0, 1, \dots, n\} \setminus I$. Obviously, the $(k+1)$ -dimensional cones of L_{k+1}^n containing σ_I are precisely the cones $\sigma_{I \cup \{j\}}$, $j \in J$. Moreover, $-e_j$ is a representative of the normal vector $u_{\sigma_{I \cup \{j\}}/\sigma_I}$. Note also that for all $i \in I'$, $I' \subsetneq \{0, 1, \dots, n\}$ we have $h_{\sigma_{I'}}(-e_i) = h|_{\sigma_{I'}}(-e_i) = h(-e_i)$. Using this we compute

$$\begin{aligned} \omega_{L_{k+1}^n, h}(\sigma_I) &= \sum_{j \in J} \underbrace{\omega_{L_{k+1}^n}(\sigma_{I \cup \{j\}})}_{=1} h_{\sigma_{I \cup \{j\}}}(-e_j) \\ &\quad + h_{\sigma_I} \left(\underbrace{\sum_{j \in J} \omega_{L_{k+1}^n}(\sigma_{I \cup \{j\}}) e_j}_{=-\sum_{i \in I} e_i} \right) \\ &= \sum_{j \in J} h(-e_j) + \sum_{i \in I} h(-e_i) \\ &= h(-e_0) + h(-e_1) + \dots + h(-e_n) \\ &= 1 + 0 + \dots + 0 = 1 = \omega_{L_k^n}(\sigma_I), \end{aligned}$$

which implies $h \cdot [L_{k+1}^n] = [L_k^n]$ and also equation $(*)$.

We can summarize this example as follows: Firstly, for a tropical polynomial f , the associated Weil divisor $f \cdot \mathbb{R}^n$ coincides with the locus of non-differentiability $\mathcal{T}(f)$ of f (see [RGST, section 3]), and secondly, “the k -fold self-intersection of a tropical hyperplane in \mathbb{R}^n ” is given by its $(n-k)$ -skeleton together with trivial weights all equal to 1.

Example 3.10 (A rigid curve). Using notations from example 3.9, we consider as ambient cycle the surface $S := [L_2^3] = \mathcal{T}(x_1 \oplus x_2 \oplus x_3 \oplus 0)$ in \mathbb{R}^3 . In this surface, we want to show that the curve $R := [(\mathbb{R} \cdot e_R, \omega_R(\mathbb{R} \cdot e_R) = 1)] \in Z_1^{\text{aff}}(S)$, where $e_R := e_1 + e_2$, has negative self-intersection in the following sense: We construct a rational function φ on S whose associated Weil divisor is R and show that $\varphi \cdot R = \varphi \cdot \varphi \cdot S$ is just the origin with weight -1 . This curve and its rigidity were first discussed in [M, Example 4.11., Example 5.9.].

Let us construct φ . First we refine L_2^3 to L_R by replacing $\sigma_{\{1,2\}}$ and $\sigma_{\{0,3\}}$ with $\sigma_{\{1,R\}}$, $\sigma_{\{R\}}$, $\sigma_{\{R,2\}}$, $\sigma_{\{0,-R\}}$, $\sigma_{\{-R\}}$ and $\sigma_{\{-R,3\}}$ (using again the notations from example 3.9 and $e_{-R} := -e_R = e_0 + e_3$). We define $\varphi : |S| \rightarrow \mathbb{R}$ to be the unique function that is linear on the faces of L_R and fulfills

$$0, -e_1, -e_2, -e_3, -e_{-R} \mapsto 0, \quad -e_0 \mapsto 1 \text{ and } -e_R \mapsto -1.$$

Analogous to 3.9, we can compute for $i = 1, 2$

$$\omega_{L_R, \varphi}(\sigma_{\{i\}}) = \varphi(-e_0) + \varphi(-e_3) + \varphi(-e_R) = 1 + 0 - 1 = 0,$$

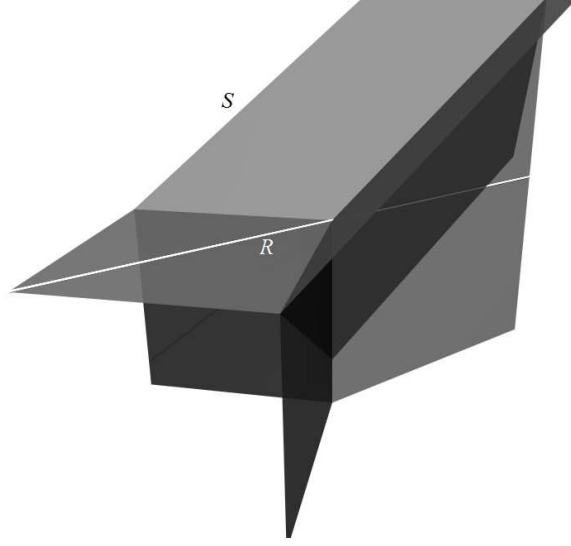
The rigid curve R in S .

for $i = 0, 3$

$$\omega_{L_R, \varphi}(\sigma_{\{i\}}) = \varphi(-e_1) + \varphi(-e_2) + \varphi(-e_{-R}) = 0 + 0 + 0 = 0,$$

and finally

$$\omega_{L_R, \varphi}(\sigma_{\{R\}}) = \varphi(-e_1) + \varphi(-e_2) - \varphi(-e_R) = 0 + 0 - (-1) = 1,$$

$$\omega_{L_R, \varphi}(\sigma_{\{-R\}}) = \varphi(-e_0) + \varphi(-e_3) - \varphi(-e_{-R}) = 1 + 0 + 0 = 1,$$

which means $\varphi \cdot S = R$. Now we can easily compute $\varphi \cdot \varphi \cdot S = \varphi \cdot R$ on the representative $\{\sigma_{\{R\}}, \sigma_{\{-R\}}, \{0\}\}$ (with trivial weights) of R :

$$\omega_{R, \varphi}(\{0\}) = \varphi(-e_R) + \varphi(-e_{-R}) = -1 + 0 = -1.$$

Therefore $\varphi \cdot \varphi \cdot S = [(\{0\}, \omega(\{0\}) = -1)]$. Note that we really obtain a cycle with negative weight, not only a cycle class modulo rational equivalence as it is the case in “classical” algebraic geometry.

4. PUSH-FORWARD OF AFFINE CYCLES AND PULL-BACK OF CARTIER DIVISORS

The aim of this section is to construct push-forwards of cycles and pull-backs of Cartier divisors along morphisms of fans and to study the interaction of both constructions. To do this we first of all have to introduce the notion of morphism:

Definition 4.1 (Morphisms of fans). Let X be a fan in $V = \Lambda \otimes_{\mathbb{Z}} \mathbb{R}$ and Y be a fan in $V' = \Lambda' \otimes_{\mathbb{Z}} \mathbb{R}$. A *morphism* $f : X \rightarrow Y$ is a \mathbb{Z} -linear map, i.e. a map from $|X| \subseteq V$ to $|Y| \subseteq V'$ induced by a \mathbb{Z} -linear map $\tilde{f} : \Lambda \rightarrow \Lambda'$. By abuse of notation we will usually denote all three maps f, \tilde{f} and $\tilde{f} \otimes_{\mathbb{Z}} \text{id}$ by the same letter f (note that the last two maps are in general not uniquely determined by $f : X \rightarrow Y$). A morphism of weighted fans is a morphism of fans. A morphism of affine cycles $f : [(X, \omega_X)] \rightarrow [(Y, \omega_Y)]$ is a morphism of fans $f : X^* \rightarrow Y^*$. Note that in this latter case the notion of morphism does not depend on the choice of the representatives by remark 2.9.

Given such a morphism the following construction shows how to build the push-forward fan of a given fan. Afterwards we will show that this construction induces a well-defined operation on cycles.

Construction 4.2. We refer to [GKM, section 2] for more details on the following construction. Let (X, ω_X) be a weighted fan of pure dimension n in $V = \Lambda \otimes_{\mathbb{Z}} \mathbb{R}$, let Y be any fan in $V' = \Lambda' \otimes_{\mathbb{Z}} \mathbb{R}$ and let $f : X \rightarrow Y$ be a morphism. Passing to an appropriate refinement of (X, ω_X) the collection of cones

$$f_*X := \{f(\sigma) \mid \sigma \in X \text{ contained in a maximal cone of } X \text{ on which } f \text{ is injective}\}$$

is a fan in V' of pure dimension n . It can be made into a weighted fan by setting

$$\omega_{f_*X}(\sigma') := \sum_{\sigma \in X^{(n)} : f(\sigma) = \sigma'} \omega_X(\sigma) \cdot |\Lambda'_{\sigma'} / f(\Lambda_{\sigma})|$$

for all $\sigma' \in f_*X^{(n)}$. The equivalence class of this weighted fan only depends on the equivalence class of (X, ω_X) .

Example 4.3. Let X be the fan with cones $\tau_1, \tau_2, \tau_3, \{0\}$ as shown in the figure

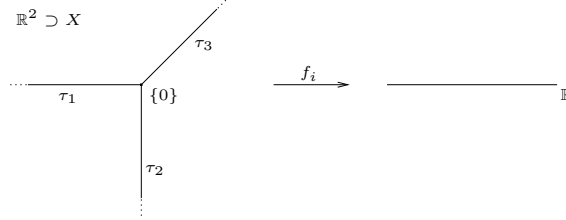

and let $\omega_X(\tau_i) = 1$ for $i = 1, 2, 3$. Moreover, let $Y := \mathbb{R}$ be the real line and the morphisms $f_1, f_2 : X \rightarrow Y$ be given by $f_1(x, y) := x + y$ and $f_2(x, y) := x$ respectively. Then $(f_1)_*X = (f_2)_*X = \{\{x \leq 0\}, \{0\}, \{x \geq 0\}\}$, but $\omega_{(f_1)_*X}(\{x \leq 0\}) = \omega_{(f_1)_*X}(\{x \geq 0\}) = 2$ and $\omega_{(f_2)_*X}(\{x \leq 0\}) = \omega_{(f_2)_*X}(\{x \geq 0\}) = 1$.

Proposition 4.4. *Let (X, ω_X) be a tropical fan of dimension n in $V = \Lambda \otimes_{\mathbb{Z}} \mathbb{R}$, let Y be any fan in $V' = \Lambda' \otimes_{\mathbb{Z}} \mathbb{R}$ and let $f : X \rightarrow Y$ be a morphism. Then f_*X is a tropical fan of dimension n .*

Proof. A proof can be found in [GKM, section 2]. □

By construction 4.2 and proposition 4.4 the following definition is well-defined:

Definition 4.5 (Push-forward of cycles). Let $V = \Lambda \otimes_{\mathbb{Z}} \mathbb{R}$ and $V' = \Lambda' \otimes_{\mathbb{Z}} \mathbb{R}$. Moreover, let $X \in Z_m^{\text{aff}}(V)$, $Y \in Z_n^{\text{aff}}(V')$ and $f : X \rightarrow Y$ be a morphism. For $[(Z, \omega_Z)] \in Z_k^{\text{aff}}(X)$ we define

$$f_*[(Z, \omega_Z)] := [(f_*(Z^*), \omega_{f_*(Z^*)})] \in Z_k^{\text{aff}}(Y).$$

Proposition 4.6 (Push-forward of cycles). *Let $V = \Lambda \otimes_{\mathbb{Z}} \mathbb{R}$ and $V' = \Lambda' \otimes_{\mathbb{Z}} \mathbb{R}$. Let $X \in Z_m^{\text{aff}}(V)$ and $Y \in Z_n^{\text{aff}}(V')$ be cycles and let $f : X \rightarrow Y$ be a morphism. Then the map*

$$Z_k^{\text{aff}}(X) \longrightarrow Z_k^{\text{aff}}(Y) : C \longmapsto f_*C$$

is well-defined and \mathbb{Z} -linear.

Proof. It remains to prove the linearity: Let (A, ω_A) and (B, ω_B) be two tropical fans of dimension k with $A = A^*$, $B = B^*$ and $|A|, |B| \subseteq |X^*|$. We want to show that $f_*(A + B) \sim f_*A + f_*B$. Refining A and B as in construction 2.13 we may assume that $A, B \subseteq A + B$. Set $\tilde{A} := A + B$ and

$$\omega_{\tilde{A}}(\sigma) := \begin{cases} \omega_A(\sigma), & \text{if } \sigma \in A \\ 0, & \text{else} \end{cases}$$

for all facets $\sigma \in \tilde{A}$. Analogously, set $\tilde{B} := A + B$ with according weights. Then $\tilde{A} \sim A$ and $\tilde{B} \sim B$. Carrying out a further refinement of $A + B$ like in construction 4.2 we can reach that $f_*(A + B) = \{f(\sigma) | \sigma \in A + B \text{ contained in a maximal cone of } A + B \text{ on which } f \text{ is injective}\}$. Using $\tilde{A} = \tilde{B} = \tilde{A} + \tilde{B} = A + B$ we get $f_*\tilde{A} = f_*\tilde{B} = f_*(\tilde{A} + \tilde{B}) = f_*(A + B)$ and it remains to compare the weights:

$$\begin{aligned} \omega_{f_*(\tilde{A} + \tilde{B})}(\sigma') &= \sum_{\sigma \in (\tilde{A} + \tilde{B})^{(k)} : f(\sigma) = \sigma'} \omega_{\tilde{A} + \tilde{B}}(\sigma) \cdot |\Lambda'_{\sigma'} / f(\Lambda_\sigma)| \\ &= \sum_{\sigma \in (\tilde{A} + \tilde{B})^{(k)} : f(\sigma) = \sigma'} [\omega_{\tilde{A}}(\sigma) + \omega_{\tilde{B}}(\sigma)] \cdot |\Lambda'_{\sigma'} / f(\Lambda_\sigma)| \\ &= \sum_{\sigma \in \tilde{A}^{(k)} : f(\sigma) = \sigma'} \omega_{\tilde{A}}(\sigma) \cdot |\Lambda'_{\sigma'} / f(\Lambda_\sigma)| + \\ &\quad \sum_{\sigma \in \tilde{B}^{(k)} : f(\sigma) = \sigma'} \omega_{\tilde{B}}(\sigma) \cdot |\Lambda'_{\sigma'} / f(\Lambda_\sigma)| \\ &= \omega_{f_*\tilde{A}}(\sigma') + \omega_{f_*\tilde{B}}(\sigma') \end{aligned}$$

for all facets σ' of $f_*(A + B)$. Hence $f_*(A + B) \sim f_*(\tilde{A} + \tilde{B}) = f_*\tilde{A} + f_*\tilde{B} \sim f_*A + f_*B$ as weighted fans. \square

Our next step is now to define the pull-back of a Cartier divisor. As promised we will prove after this a projection formula that describes the interaction between our two constructions.

Proposition 4.7 (Pull-back of Cartier divisors). *Let $C \in Z_m^{\text{aff}}(V)$ and $D \in Z_n^{\text{aff}}(V')$ be cycles in $V = \Lambda \otimes_{\mathbb{Z}} \mathbb{R}$ and $V' = \Lambda' \otimes_{\mathbb{Z}} \mathbb{R}$ respectively and let $f : C \rightarrow D$ be a morphism. Then there is a well-defined and \mathbb{Z} -linear map*

$$\text{Div}(D) \longrightarrow \text{Div}(C) : [h] \longmapsto f^*[h] := [h \circ f].$$

Proof. The map $h \mapsto h \circ f$ is obviously \mathbb{Z} -linear on rational functions and maps affine linear functions to affine linear functions. Thus it remains to prove that $h \circ f$ is a rational function if h is one: Therefore let (X, ω_X) be any representative of C , let (Y, ω_Y) be a reduced representative of D such that the restriction of h to every cone in Y is affine linear and let $f_V : V \rightarrow V'$ be a \mathbb{Z} -linear map such that $f_V|_{|C|} = f$. Since $Z := \{f_V^{-1}(\sigma') | \sigma' \in Y\}$ is a fan in V and $|X| \subseteq |Z|$ we can construct the refinement $\tilde{X} := X \cap Z$ of X such that $h \circ f$ is affine linear on every cone of \tilde{X} . This finishes the proof. \square

Proposition 4.8 (Projection formula). *Let $C \in Z_m^{\text{aff}}(V)$ and $D \in Z_n^{\text{aff}}(V')$ be cycles in $V = \Lambda \otimes_{\mathbb{Z}} \mathbb{R}$ and $V' = \Lambda' \otimes_{\mathbb{Z}} \mathbb{R}$ respectively and let $f : C \rightarrow D$ be a morphism. Let $E \in Z_k^{\text{aff}}(C)$ be a cycle and let $\varphi \in \text{Div}(D)$ be a Cartier divisor. Then the following equation holds:*

$$\varphi \cdot (f_*E) = f_*(f^*\varphi \cdot E) \in Z_{k-1}^{\text{aff}}(D).$$

Proof. Let $E = [(Z, \omega_Z)]$ and $\varphi = [h]$. We may assume that $Z = Z^*$ and $h(0) = 0$. Replacing Z by a refinement we may additionally assume that f^*h is linear on every cone of Z (cf. definition 3.1) and that

$$f_*Z = \{f(\sigma) \mid \sigma \in Z \text{ contained in a maximal cone of } Z \text{ on which } f \text{ is injective}\}$$

(cf. construction 4.2). Note that in this case h is linear on the cones of f_*Z , too. Let $\sigma' \subseteq |D|$ be a cone (not necessarily $\sigma' \in f_*Z$) such that h is linear on σ' . Then there is a unique linear map $h_{\sigma'} : V_{\sigma'}' \rightarrow \mathbb{R}$ induced by the restriction $h|_{\sigma'}$. Analogously for $f^*h_{\sigma}, \sigma \subseteq |C|$. For cones $\tau < \sigma \in Z$ of dimension $k-1$ and k respectively let $v_{\sigma/\tau} \in \Lambda$ be a representative of the primitive normal vector $u_{\sigma/\tau} \in \Lambda/\Lambda_{\tau}$ of construction 2.3. Analogously, for $\tau' < \sigma' \in f_*Z$ of dimension $k-1$ and k respectively let $v_{\sigma'/\tau'}$ be a representative of $u_{\sigma'/\tau'} \in \Lambda'/\Lambda_{\tau'}'$. Now we want to compare the weighted fans $h \cdot (f_*Z)$ and $f_*(f^*h \cdot Z)$: Let $\tau' \in f_*Z$ be a cone of dimension $k-1$. Then we can calculate the weight of τ' in $h \cdot (f_*Z)$ as follows:

$$\begin{aligned} \omega_{h \cdot (f_*Z)}(\tau') &= \left(\sum_{\sigma' \in f_*Z: \sigma' > \tau'} \omega_{f_*Z}(\sigma') \cdot h_{\sigma'}(v_{\sigma'/\tau'}) \right) \\ &\quad - h_{\tau'} \left(\sum_{\sigma' \in f_*Z: \sigma' > \tau'} \omega_{f_*Z}(\sigma') \cdot v_{\sigma'/\tau'} \right) \\ &= \left(\sum_{\sigma' \in f_*Z: \sigma' > \tau'} \left(\sum_{\sigma \in Z^{(k)}: f(\sigma) = \sigma'} \omega_Z(\sigma) \cdot |\Lambda_{\sigma'}'/f(\Lambda_{\sigma})| \right) \cdot h_{\sigma'}(v_{\sigma'/\tau'}) \right) \\ &\quad - h_{\tau'} \left(\sum_{\sigma' \in f_*Z: \sigma' > \tau'} \left(\sum_{\sigma \in Z^{(k)}: f(\sigma) = \sigma'} \omega_Z(\sigma) \cdot |\Lambda_{\sigma'}'/f(\Lambda_{\sigma})| \right) \cdot v_{\sigma'/\tau'} \right) \\ &= \left(\sum_{\sigma \in Z^{(k)}: f(\sigma) > \tau'} \omega_Z(\sigma) \cdot |\Lambda_{f(\sigma)}'/f(\Lambda_{\sigma})| \cdot h_{f(\sigma)}(v_{f(\sigma)/\tau'}) \right) \\ &\quad - h_{\tau'} \left(\sum_{\sigma \in Z^{(k)}: f(\sigma) > \tau'} \omega_Z(\sigma) \cdot |\Lambda_{f(\sigma)}'/f(\Lambda_{\sigma})| \cdot v_{f(\sigma)/\tau'} \right) \end{aligned}$$

Now let $\tau' \in f_*(f^*h \cdot Z)$ of dimension $k-1$. The weight of τ' in $f_*(f^*h \cdot Z)$ can be calculated as follows:

$$\begin{aligned} \omega_{f_*(f^*h \cdot Z)}(\tau') &= \sum_{\substack{\tau \in (f^*h \cdot Z)^{(k-1)} \\ f(\tau) = \tau'}} \omega_{f^*h \cdot Z}(\tau) \cdot |\Lambda_{\tau'}'/f(\Lambda_{\tau})| \\ &= \sum_{\substack{\tau \in (f^*h \cdot Z)^{(k-1)} \\ f(\tau) = \tau'}} \left(\sum_{\sigma \in Z^{(k)}: \sigma > \tau} \omega_Z(\sigma) f^*h_{\sigma}(v_{\sigma/\tau}) \right. \\ &\quad \left. - f^*h_{\tau} \left(\sum_{\sigma \in Z^{(k)}: \sigma > \tau} \omega_Z(\sigma) \cdot v_{\sigma/\tau} \right) \right) \cdot |\Lambda_{\tau'}'/f(\Lambda_{\tau})| \end{aligned}$$

$$\begin{aligned}
&= \sum_{\substack{\tau \in (f^*h \cdot Z)^{(k-1)} \\ f(\tau) = \tau'}} \left(\sum_{\sigma \in Z^{(k)} : \sigma > \tau} \omega_Z(\sigma) h_{f(\sigma)}(f(v_{\sigma/\tau})) \right. \\
&\quad \left. - h_{f(\tau)} \left(\sum_{\sigma \in Z^{(k)} : \sigma > \tau} \omega_Z(\sigma) \cdot f(v_{\sigma/\tau}) \right) \right) \cdot |\Lambda'_{\tau'} / f(\Lambda_\tau)|.
\end{aligned}$$

Note that $f(v_{\sigma/\tau}) = |\Lambda'_{\sigma'} / (\Lambda'_{\sigma'} + \mathbb{Z}f(v_{\sigma/\tau}))| \cdot v_{\sigma'/\tau'} + \lambda_{\sigma,\tau} \in \Lambda'$ for some $\lambda_{\sigma,\tau} \in \Lambda'_{\tau'}$. Since $h_{f(\sigma)}(\lambda_{\sigma,\tau}) = h_{f(\tau)}(\lambda_{\sigma,\tau})$ these parts of the corresponding summands in the first and second interior sum cancel using the linearity of $h_{f(\tau)}$. Moreover, note that $f(v_{\sigma/\tau}) = \lambda_{\sigma,\tau} \in \Lambda'_{\tau'}$ for those $\sigma > \tau$ on which f is not injective and that the whole summands cancel in this case. Thus we can conclude that the sum does not change if we restrict the summation to those $\sigma > \tau$ on which f is injective. Using additionally the equation

$$|\Lambda'_{\sigma'} / f(\Lambda_\sigma)| = |\Lambda'_{\tau'} / f(\Lambda_\tau)| \cdot |\Lambda'_{\sigma'} / (\Lambda'_{\tau'} + \mathbb{Z}f(v_{\sigma/\tau}))|$$

we get

$$\begin{aligned}
\omega_{f_*(f^*h \cdot Z)}(\tau') &= \sum_{\substack{\tau \in (f^*h \cdot Z)^{(k-1)} \\ f(\tau) = \tau'}} \left(\sum_{\substack{\sigma \in Z^{(k)} \\ \sigma > \tau, f(\sigma) > \tau'}} \omega_Z(\sigma) \cdot |\Lambda'_{f(\sigma)} / f(\Lambda_\sigma)| \cdot h_{f(\sigma)}(v_{f(\sigma)/\tau'}) \right. \\
&\quad \left. - h_{\tau'} \left(\sum_{\substack{\sigma \in Z^{(k)} \\ \sigma > \tau, f(\sigma) > \tau'}} \omega_Z(\sigma) \cdot |\Lambda'_{f(\sigma)} / f(\Lambda_\sigma)| \cdot v_{f(\sigma)/\tau'} \right) \right) \\
&= \left(\sum_{\sigma \in Z^{(k)} : f(\sigma) > \tau'} \omega_Z(\sigma) \cdot |\Lambda'_{f(\sigma)} / f(\Lambda_\sigma)| \cdot h_{f(\sigma)}(v_{f(\sigma)/\tau'}) \right) \\
&\quad - h_{\tau'} \left(\sum_{\sigma \in Z^{(k)} : f(\sigma) > \tau'} \omega_Z(\sigma) \cdot |\Lambda'_{f(\sigma)} / f(\Lambda_\sigma)| \cdot v_{f(\sigma)/\tau'} \right).
\end{aligned}$$

Note that for the last equation we used again the linearity of $h_{\tau'}$. We have checked so far that a cone τ' of dimension $k-1$ occurring in both $h \cdot (f_*Z)$ and $f_*(f^*h \cdot Z)$ has the same weight in both fans. Thus it remains to examine those cones $f(\tau), \tau \in Z^{(k-1)}$ such that f is injective on τ but not on any $\sigma > \tau$: In this case all vectors $v_{\sigma/\tau}$ are mapped to $\Lambda'_{f(\tau)}$. Again, $h_{f(\sigma)} = h_{f(\tau)}$ and by linearity of $h_{f(\tau)}$ all summands in the sum cancel as above. Hence the weight of $f(\tau)$ in $f_*(f^*h \cdot Z)$ is 0 and $\varphi \cdot (f_*E) = [h \cdot (f_*Z)] = [f_*(f^*h \cdot Z)] = f_*(f^*\varphi \cdot E)$. \square

5. ABSTRACT TROPICAL CYCLES

In this section we will introduce the notion of abstract tropical cycles as spaces that have tropical fans as local building blocks. Then we will generalize the theory from the previous sections to these spaces.

Definition 5.1 (Abstract polyhedral complexes). An *(abstract) polyhedral complex* is a topological space $|X|$ together with a finite set X of closed subsets of $|X|$ and an embedding map $\varphi_\sigma : \sigma \rightarrow \mathbb{R}^{n_\sigma}$ for every $\sigma \in X$ such that

- (a) X is closed under taking intersections, i.e. $\sigma \cap \sigma' \in X$ for all $\sigma, \sigma' \in X$ with $\sigma \cap \sigma' \neq \emptyset$,
- (b) every image $\varphi_\sigma(\sigma)$, $\sigma \in X$ is a rational polyhedron not contained in a proper affine subspace of \mathbb{R}^{n_σ} ,
- (c) for every pair $\sigma, \sigma' \in X$ the concatenation $\varphi_\sigma \circ \varphi_{\sigma'}^{-1}$ is integer affine linear where defined,
- (d) $|X| = \bigcup_{\sigma \in X} \varphi_\sigma^{-1}(\varphi_\sigma(\sigma)^\circ)$, where $\varphi_\sigma(\sigma)^\circ$ denotes the interior of $\varphi_\sigma(\sigma)$ in \mathbb{R}^{n_σ} .

For simplicity we will usually drop the embedding maps φ_σ and denote the polyhedral complex $(X, |X|, \{\varphi_\sigma | \sigma \in X\})$ by $(X, |X|)$ or just by X if no confusion can occur. The closed subsets $\sigma \in X$ are called the *polyhedra* or *faces* of $(X, |X|)$. For $\sigma \in X$ the open set $\sigma^{ri} := \varphi_\sigma^{-1}(\varphi_\sigma(\sigma)^\circ)$ is called the *relative interior* of σ . Like in the case of fans the *dimension* of $(X, |X|)$ is the maximum of the dimensions of its polyhedra. $(X, |X|)$ is *pure-dimensional* if every inclusion-maximal polyhedron has the same dimension. We denote by $X^{(n)}$ the set of polyhedra in $(X, |X|)$ of dimension n . Let $\tau, \sigma \in X$. Like in the case of fans we write $\tau \leq \sigma$ (or $\tau < \sigma$) if $\tau \subseteq \sigma$ (or $\tau \subsetneq \sigma$ respectively).

An abstract polyhedral complex $(X, |X|)$ of pure dimension n together with a map $\omega_X : X^{(n)} \rightarrow \mathbb{Z}$ is called *weighted polyhedral complex* of dimension n and $\omega_X(\sigma)$ the *weight* of the polyhedron $\sigma \in X^{(n)}$. Like in the case of fans the empty complex \emptyset is a weighted polyhedral complex of every dimension n . If $((X, |X|), \omega_X)$ is a weighted polyhedral complex of dimension n then let

$$X^* := \{\tau \in X | \tau \subseteq \sigma \text{ for some } \sigma \in X^{(n)} \text{ with } \omega_X(\sigma) \neq 0\}, |X^*| := \bigcup_{\tau \in X^*} \tau \subseteq |X|.$$

With these definitions $((X^*, |X^*|), \omega_X|_{(X^*)^{(n)}})$ is again a weighted polyhedral complex of dimension n , called the *non-zero part* of $((X, |X|), \omega_X)$. We call a weighted polyhedral complex $((X, |X|), \omega_X)$ *reduced* if $((X, |X|), \omega_X) = ((X^*, |X^*|), \omega_X)$ holds.

Definition 5.2 (Subcomplexes and refinements). Let $(X, |X|, \{\varphi_\sigma\})$ and $(Y, |Y|, \{\psi_\tau\})$ be two polyhedral complexes. We call $(X, |X|, \{\varphi_\sigma\})$ a *subcomplex* of $(Y, |Y|, \{\psi_\tau\})$ if

- (a) $|X| \subseteq |Y|$,
- (b) for every $\sigma \in X$ exists $\tau \in Y$ with $\sigma \subseteq \tau$ and
- (c) the \mathbb{Z} -linear structures of X and Y are compatible, i.e. for a pair σ, τ from (b) the maps $\varphi_\sigma \circ \psi_\tau^{-1}$ and $\psi_\tau \circ \varphi_\sigma^{-1}$ are integer affine linear where defined.

We write $(X, |X|, \{\varphi_\sigma\}) \trianglelefteq (Y, |Y|, \{\psi_\tau\})$ in this case. Analogous to the case of fans we define a map $C_{X,Y} : X \rightarrow Y$ that maps a polyhedron in X to the inclusion-minimal polyhedron in Y containing it.

We call a weighted polyhedral complex $((X, |X|), \omega_X)$ a *refinement* of $((Y, |Y|), \omega_Y)$ if

- (a) $(X^*, |X^*|) \trianglelefteq (Y^*, |Y^*|)$,
- (b) $|X^*| = |Y^*|$,
- (c) $\omega_X(\sigma) = \omega_Y(C_{X^*,Y^*}(\sigma))$ for all $\sigma \in (X^*)^{(\dim(X))}$.

Definition 5.3 (Open fans). Let $(\tilde{F}, \omega_{\tilde{F}})$ be a tropical fan in \mathbb{R}^n and $U \subseteq \mathbb{R}^n$ an open subset containing the origin. The set $F := \tilde{F} \cap U := \{\sigma \cap U | \sigma \in \tilde{F}\}$ together with the

induced weight function ω_F is called an *open (tropical) fan* in \mathbb{R}^n . Like in the case of fans let $|F| := \bigcup_{\sigma' \in F} \sigma'$. Note that the open fan F contains the whole information of the entire fan \tilde{F} as $\tilde{F} = \{\mathbb{R}_{\geq 0} \cdot \sigma' \mid \sigma' \in F\}$.

Definition 5.4 (Tropical polyhedral complexes). A *tropical polyhedral complex* of dimension n is a weighted polyhedral complex $((X, |X|), \omega_X)$ of pure dimension n together with the following data: For every polyhedron $\sigma \in X^*$ we are given an open fan F_σ in some \mathbb{R}^{n_σ} and a homeomorphism

$$\Phi_\sigma : S_\sigma := \bigcup_{\sigma' \in X^*, \sigma' \supseteq \sigma} (\sigma')^{r_i} \xrightarrow{\sim} |F_\sigma|$$

such that

- (a) for all $\sigma' \in X^*, \sigma' \supseteq \sigma$ holds $\Phi_\sigma(\sigma' \cap S_\sigma) \in F_\sigma$ and Φ_σ is compatible with the \mathbb{Z} -linear structure on σ' , i.e. $\Phi_\sigma \circ \varphi_{\sigma'}^{-1}$ and $\varphi_{\sigma'} \circ \Phi_\sigma^{-1}$ are integer affine linear where defined,
- (b) $\omega_X(\sigma') = \omega_{F_\sigma}(\Phi_\sigma(\sigma' \cap S_\sigma))$ for every $\sigma' \in (X^*)^{(n)}$ with $\sigma' \supseteq \sigma$,
- (c) for every pair $\sigma, \tau \in X^*$ there is an integer affine linear map $A_{\sigma, \tau}$ and a commutative diagram

$$\begin{array}{ccc} S_\sigma \cap S_\tau & \xrightarrow[\sim]{\Phi_\tau} & \Phi_\tau(S_\sigma \cap S_\tau) \\ \Phi_\sigma \downarrow \sim & \nearrow A_{\sigma, \tau} & \\ \Phi_\sigma(S_\sigma \cap S_\tau) & & \end{array}$$

For simplicity of notation we will usually drop the maps Φ_σ and write $((X, |X|), \omega_X)$ or just X instead of $((X, |X|), \omega_X, \{\Phi_\sigma\})$. A tropical polyhedral complex is called *reduced* if the underlying weighted polyhedral complex is.

Example 5.5. The following figure shows the topological spaces and the decompositions into polyhedra of two such abstract tropical polyhedral complexes together with the open fan F_σ for every polyhedron σ :

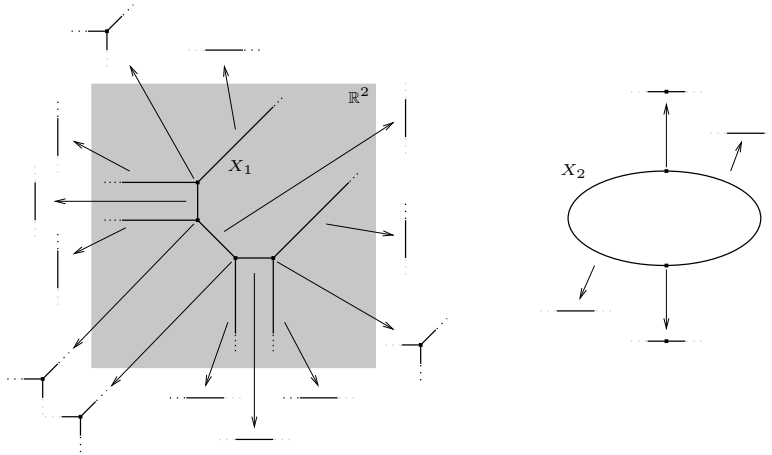

Construction 5.6 (Refinements of tropical polyhedral complexes). Let $((X, |X|), \omega_X, \{\Phi_\sigma\})$ be a tropical polyhedral complex and let $((Y, |Y|), \omega_Y)$ be a refinement of its underlying weighted polyhedral complex $((X, |X|), \omega_X)$. Then we can

make $((Y, |Y|), \omega_Y)$ into a tropical polyhedral complex as follows: We may assume that X and Y are reduced as we do not pose any conditions on polyhedra with weight zero. Fix some $\tau \in Y$ and let $\sigma := C_{Y,X}(\tau)$. By definition of refinement, for every $\tau' \in Y$ with $\tau' \geq \tau$ there is $\sigma' \in X$, $\sigma' \geq \sigma$ with $\tau' \subseteq \sigma'$. Thus $S_\tau \subseteq S_{\sigma'}$ and we have a map $\Psi_\tau := \Phi_\sigma|_{S_\tau} : S_\tau \xrightarrow{\sim} \Psi_\tau(S_\tau) \subseteq \mathbb{R}^{n_\sigma}$. It remains to give $\Psi_\tau(S_\tau)$ the structure of an open fan: We may assume that $\{0\} \subseteq \Psi_\tau(\tau)$ (otherwise replace Ψ_τ by the concatenating of Ψ_τ with an appropriate translation T_τ , apply T_τ to F_σ^X and Φ_σ and change the maps $A_{\sigma,\sigma'}$ and $A_{\sigma',\sigma}$ accordingly). Let $\tilde{F}_\sigma^X := \{\mathbb{R}_{\geq 0} \cdot \sigma' \mid \sigma' \in F_\sigma^X\}$ be the tropical fan associated to F_σ^X and let \tilde{F}_τ^Y be the set of cones $\tilde{F}_\tau^Y := \{\mathbb{R}_{\geq 0} \cdot \Psi_\tau(\tau') \mid \tau \leq \tau' \in Y\}$. Note that the conditions on the \mathbb{Z} -linear structures on X and Y to be compatible and on Φ_σ to be compatible with the \mathbb{Z} -linear structure on X assure that \tilde{F}_τ^Y is a fan in \mathbb{R}^{n_σ} . In fact, \tilde{F}_τ^Y with the weights induced by Y is a refinement of $(\tilde{F}_\sigma^X, \omega_{\tilde{F}_\sigma^X})$. Thus the maps Ψ_τ together with the open fans $\{\varrho \cap \Psi_\tau(S_\tau) \mid \varrho \in \tilde{F}_\tau^Y\}$, $\tau \in Y$ fulfill all requirements for a tropical polyhedral complex.

Remark 5.7. If not stated otherwise we will from now on equip every refinement of a tropical polyhedral complex coming from a refinement of the underlying weighted polyhedral complex with the tropical structure constructed in 5.6.

Definition 5.8 (Refinements and equivalence of tropical polyhedral complexes). Let $C_1 = (((X_1, |X_1|), \omega_{X_1}), \{\Phi_{\sigma_1}^{X_1}\})$ and $C_2 = (((X_2, |X_2|), \omega_{X_2}), \{\Phi_{\sigma_2}^{X_2}\})$ be tropical polyhedral complexes. We call C_2 a *refinement* of C_1 if

- (a) $((X_2, |X_2|), \omega_{X_2})$ is a refinement of $((X_1, |X_1|), \omega_{X_1})$ and
- (b) C_2 carries the tropical structure induced by C_1 like in construction 5.6, i.e. if $C_2' = (((X_2, |X_2|), \omega_{X_2}), \{\tilde{\Phi}_{\sigma_2}^{X_2}\})$ is the tropical polyhedral complex obtained from C_1 and the refinement $((X_2, |X_2|), \omega_{X_2})$ then the maps $\tilde{\Phi}_{\sigma_2}^{X_2} \circ (\Phi_{\sigma_2}^{X_2})^{-1}$ and $\Phi_{\sigma_2}^{X_2} \circ (\tilde{\Phi}_{\sigma_2}^{X_2})^{-1}$ are integer affine linear where defined.

We call two tropical polyhedral complexes C_1 and C_2 *equivalent* (write $C_1 \sim C_2$) if they have a common refinement (as tropical polyhedral complexes).

Remark 5.9. Note that different choices of translation maps T_τ in construction 5.6 only lead to tropical polyhedral complexes carrying the same tropical structure in the sense of definition 5.8 (b). In particular definition 5.8 does not depend on the choices we made in construction 5.6. Note moreover that refinements of $((X, |X|), \omega_X, \{\Phi_\sigma\})$ and $((Y, |Y|), \omega_Y)$ in construction 5.6 only lead to refinements of $((Y, |Y|), \omega_Y, \{\Psi_\tau\})$.

Construction 5.10. (Refinements) Let $((X, |X|, \{\varphi_\sigma\}), \omega_X, \{\Phi_\sigma\})$ and $((Y, |Y|, \{\psi_\tau\}), \omega_Y, \{\Psi_\tau\})$ be reduced tropical polyhedral complexes such that $(Y, |Y|) \trianglelefteq (X, |X|)$ and the tropical structures on X and Y agree, i.e. for every $\tau \in Y$ and $\sigma := C_{Y,X}(\tau) \in X$ the maps $\Psi_\tau \circ \Phi_\sigma^{-1}$ and $\Phi_\sigma \circ \Psi_\tau^{-1}$ are integer affine linear where defined. Moreover let $((X', |X'|, \{\varphi_{\sigma'}\}), \omega_{X'}, \{\Phi_{\sigma'}\})$ be a reduced refinement of $((X, |X|, \{\varphi_\sigma\}), \omega_X, \{\Phi_\sigma\})$. Like in the case of fans we will construct a refinement $((Y \cap X', |Y \cap X'|, \{\psi_\tau^{Y \cap X'}\}), \omega_{Y \cap X'}, \{\Psi_\tau^{Y \cap X'}\})$ of $((Y, |Y|, \{\psi_\tau\}), \omega_Y, \{\Psi_\tau\})$ such that $(Y \cap X', |Y \cap X'|) \trianglelefteq (X', |X'|)$ and the tropical structures on $Y \cap X'$ and X' agree:

Fix $\sigma \in X$. Note that the compatibility conditions on the \mathbb{Z} -linear structures of X' , X and Y , X respectively (cf. 5.2 (c)) assure that $\varphi_\sigma(\sigma')$, $\sigma' \in X'$ with $\sigma' \subseteq \sigma$ as

well as $\varphi_\sigma(\tau)$, $\tau \in Y$ with $\tau \subseteq \sigma$ are rational polyhedra in \mathbb{R}^{n_σ} . Thus in this case $\varphi_\sigma(\sigma' \cap \tau) = \varphi_\sigma(\sigma') \cap \varphi_\sigma(\tau)$ is a rational polyhedron, too. Let $H_{\sigma', \tau} \cong \mathbb{R}^{n_\tau}$ be the smallest affine subspace of \mathbb{R}^{n_σ} containing $\varphi_\sigma(\sigma' \cap \tau)$. We can consider $\varphi_\sigma|_{\sigma' \cap \tau}$ to be a map $\sigma' \cap \tau \rightarrow \mathbb{R}^{n_\tau}$. We can hence construct the underlying weighted polyhedral complex of our desired tropical polyhedral complex as follows: Set $P := \{\tau \cap \sigma' \mid \tau \in Y, \sigma' \in X'\}$, $Y \cap X' := \{\tau \in P \mid \exists \tilde{\tau} \in P^{(\dim(\tau))} : \tilde{\tau} \subsetneq \tau\}$, $|Y \cap X'| := |Y|$ and $\omega_{Y \cap X'}(\tau) := \omega_Y(C_{Y \cap X', Y}(\tau))$ for all $\tau \in (Y \cap X')^{(\dim(Y))}$. It remains to define the maps $\psi_{\tau'}^{Y \cap X'}$ and $\Psi_{\tau'}^{Y \cap X'}$: For every $\tau' \in Y \cap X'$ choose a triplet $\sigma' \in X', \tau \in Y, \sigma \in X$ such that $\sigma' \cap \tau = \tau'$ and $\sigma', \tau \subseteq \sigma$ and set $\psi_{\tau'}^{Y \cap X'} := \varphi_\sigma|_{\sigma' \cap \tau}$. With these definitions the weighted polyhedral complex $((Y \cap X', |Y \cap X'|, \{\psi_{\tau'}^{Y \cap X'}\}), \omega_{Y \cap X'})$ is a refinement of $((Y, |Y|, \{\psi_\tau\}), \omega_Y)$. Thus we can apply construction 5.6 to obtain maps $\{\Psi_{\tau'}^{Y \cap X'}\}$ that endow our weighted polyhedral complex with the tropical structure inherited from $((Y, |Y|, \{\psi_\tau\}), \omega_Y)$. Note that the compatibility property between the tropical structures of Y and X is bequeathed to $Y \cap X'$ and X' , too.

Lemma 5.11. *The equivalence of tropical polyhedral complexes is an equivalence relation.*

Proof. Let $C_1 = (((X_1, |X_1|), \omega_{X_1}), \{\Phi_{\sigma_1}^{X_1}\})$, $C_2 = (((X_2, |X_2|), \omega_{X_2}), \{\Phi_{\sigma_2}^{X_2}\})$ and $C_3 = (((X_3, |X_3|), \omega_{X_3}), \{\Phi_{\sigma_3}^{X_3}\})$ be tropical polyhedral complexes such that $C_1 \sim C_2$ via a common refinement $D_1 = (((Y_1, |Y_1|), \omega_{Y_1}), \{\Phi_{\sigma_1}^{Y_1}\})$ and $C_2 \sim C_3$ via a common refinement $D_2 = (((Y_2, |Y_2|), \omega_{Y_2}), \{\Phi_{\sigma_2}^{Y_2}\})$. We have to construct a common refinement of C_1 and C_3 : First of all we may assume that D_1 and D_2 are reduced. Using construction 5.10 we get a refinement $D_3 := (((Y_1 \cap Y_2, |Y_1 \cap Y_2|), \omega_{Y_1 \cap Y_2}), \{\Phi_{\sigma}^{Y_1 \cap Y_2}\})$ of D_1 with $(Y_1 \cap Y_2, |Y_1 \cap Y_2|) \trianglelefteq (Y_2, |Y_2|)$ and a tropical structure that is compatible with the tropical structure on D_2 . It is easily checked that D_3 is a refinement of D_2 , too. \square

Definition 5.12 (Abstract tropical cycles). Let $((X, |X|), \omega_X)$ be an n -dimensional tropical polyhedral complex. Its equivalence class $[((X, |X|), \omega_X)]$ is called an *(abstract) tropical n -cycle*. The set of n -cycles is denoted by Z_n . Since the topological space $|X^*|$ of a tropical polyhedral complex $((X, |X|), \omega_X)$ is by definition invariant under refinements we define $[((X, |X|), \omega_X)] := |X^*|$. Like in the affine case, an n -cycle $((X, |X|), \omega_X)$ is called an *(abstract) tropical variety* if $\omega_X(\sigma) \geq 0$ for all $\sigma \in X^{(n)}$.

Let $C \in Z_n$ and $D \in Z_k$ be two tropical cycles. D is called an *(abstract) tropical cycle in C* or a *subcycle of C* if there exists a representative $((Z, |Z|), \omega_Z, \{\Psi_\tau\})$ of D and a reduced representative $((X, |X|), \omega_X, \{\Phi_\sigma\})$ of C such that

- (a) $(Z, |Z|) \trianglelefteq (X, |X|)$,
- (b) the tropical structures on Z and X agree, i.e. for every $\tau \in Z$ the maps $\Psi_\tau \circ \Phi_{C_{Z, X}(\tau)}^{-1}$ and $\Phi_{C_{Z, X}(\tau)} \circ \Psi_\tau^{-1}$ are integer affine linear where defined.

The set of tropical k -cycles in C is denoted by $Z_k(C)$.

Remark and Definition 5.13. (a) Let X be a finite set of rational polyhedra in \mathbb{R}^n , $f \in \text{Hom}(\mathbb{Z}^n, \mathbb{Z})$ a linear form and $b \in \mathbb{R}$. Then let

$$H_{f, b} := \{x \in \mathbb{R}^n \mid f(x) \leq b\}, \{x \in \mathbb{R}^n \mid f(x) = b\}, \{x \in \mathbb{R}^n \mid f(x) \geq b\}.$$

Like in the case of fans (cf. construction 2.10) we can form sets $P := \{\sigma \cap \sigma' \mid \sigma \in X, \sigma' \in H_{f, b}\}$ and $X \cap H_{f, b} := \{\sigma \in P \mid \exists \tau \in P^{(\dim(\sigma))} \text{ with } \tau \subsetneq \sigma\}$.

(b) Again let X be a finite set of rational polyhedra in \mathbb{R}^n . Let $\{f_i \leq b_i | i = 1, \dots, N\}$ be all (integral) inequalities occurring in the description of all polyhedra in X . Then we can construct the set $X \cap H_{f_1, b_1} \cap \dots \cap H_{f_N, b_N}$. Note that for every collection of polyhedra X this set $X \cap H_{f_1, b_1} \cap \dots \cap H_{f_N, b_N}$ is a (usual) rational polyhedral complex (i.e. for every polyhedron $\tau \in X$ every face (in the usual sense) of σ is contained in X and the intersection of every two polyhedra in X is a common face of each). Moreover note that the result is independent of the order of the f_i and if $\{g_i \leq c_i | i = 1, \dots, M\}$ is a different set of inequalities describing the polyhedra in X then $X \cap H_{f_1, b_1} \cap \dots \cap H_{f_N, b_N}$ and $X \cap H_{g_1, c_1} \cap \dots \cap H_{g_M, c_M}$ have a common refinement, namely $X \cap H_{f_1, b_1} \cap \dots \cap H_{f_N, b_N} \cap H_{g_1, c_1} \cap \dots \cap H_{g_M, c_M}$.

Construction 5.14 (Sums of tropical cycles). Let $C \in Z_n$ be a tropical cycle. Like in the affine case the set of tropical k -cycles in C can be made into an abelian group by defining the sum of two such k -cycles as follows: Let D_1 and $D_2 \in Z_k(C)$ be the two cycles whose sum we want to construct. By definition there are reduced representatives $((X_1, |X_1|), \omega_{X_1}, \{\Phi_\tau^{X_1}\})$ and $((X_2, |X_2|), \omega_{X_2}, \{\Phi_\tau^{X_2}\})$ of C and reduced representatives $((Y, |Y|), \omega_Y, \{\Phi_\tau^Y\})$ of D_1 and $((Z, |Z|), \omega_Z, \{\Phi_\tau^Z\})$ of D_2 such that $(Y, |Y|) \leq (X_1, |X_1|)$ and the tropical structures on Y and X_1 agree and $(Z, |Z|) \leq (X_2, |X_2|)$ and the tropical structures on Z and X_2 agree. As “ \sim ” is an equivalence relation there is a common refinement $((X, |X|), \omega_X, \{\Phi_\tau^X\})$ of X_1 and X_2 which we may assume to be reduced. Applying construction 5.10 to Y and X we obtain the tropical polyhedral complex $((Y \cap X, |Y \cap X|), \omega_{Y \cap X}, \{\Phi_\tau^{Y \cap X}\})$ which is a refinement of Y , has a tropical structure that is compatible with the tropical structure on X and fulfils $(Y \cap X, |Y \cap X|) \leq (X, |X|)$. If we further apply construction 5.10 to Z and X we get a refinement $((Z \cap X, |Z \cap X|), \omega_{Z \cap X}, \{\Phi_\tau^{Z \cap X}\})$ of Z with analogous properties. Now fix some polyhedron $\sigma \in X$ and let $\tau_1, \dots, \tau_r \in Y \cap X$ and $\tau_{r+1}, \dots, \tau_s \in Z \cap X$ be all polyhedra of $Y \cap X$ and $Z \cap X$ respectively that are contained in σ . Note that property (a) of definition 5.12 implies that for all $i = 1, \dots, r$ the image $\varphi_\sigma(\tau_i)$ is a rational polyhedron in \mathbb{R}^{n_σ} . Like in remark and definition 5.13 let $\{f_i \leq b_i | i = 1, \dots, N\}$ be the set of all integral inequalities occurring in the description of all polyhedra $\varphi_\sigma(\tau_i)$, $i = 1, \dots, s$ and let $R_{Y \cap X}^\sigma := \{\varphi_\sigma(\tau_i) | i = 1, \dots, r\} \cap H_{f_1, b_1} \cap \dots \cap H_{f_N, b_N}$ and $R_{Z \cap X}^\sigma := \{\varphi_\sigma(\tau_i) | i = r+1, \dots, s\} \cap H_{f_1, b_1} \cap \dots \cap H_{f_N, b_N}$. Then $P_{Y \cap X}^\sigma := \{\varphi_\sigma^{-1}(\tau) | \tau \in R_{Y \cap X}^\sigma\}$ and $P_{Z \cap X}^\sigma := \{\varphi_\sigma^{-1}(\tau) | \tau \in R_{Z \cap X}^\sigma\}$ are a kind of local refinement of $Y \cap X$ and $Z \cap X$ respectively, but taking the union over all maximal polyhedra $\sigma \in X^{(n)}$ does in general not lead to global refinements as there may be overlaps between polyhedra coming from different σ . We resolve this as follows: For $\sigma \in X^{(n)}$, $\tau \in \bigcup_{i=0}^{n-1} X^{(i)}$ let $P_{Y, \tau}^\sigma := \{\varrho \in P_{Y \cap X}^\sigma | \tau \text{ is the inclusion-minimal polyhedron of } X \text{ containing } \varrho\}$ and $P_{Y, n} := \bigcup_{\sigma \in X^{(n)}} \{\varrho \in P_{Y \cap X}^\sigma | \exists \tilde{\tau} \in X^{(n-1)} : \varrho \subseteq \tilde{\tau}\}$. Analogously for $P_{Z, \tau}^\sigma$ and $P_{Z, n}$. Then let $\tilde{Y} := P_{Y, n} \cup \left(\bigcup_{\tau \in X^{(i)} : i < n} \{\bigcap_{\sigma \in X^{(n)} : \tau \subseteq \sigma} \tau_\sigma | \tau_\sigma \in P_{Y, \tau}^\sigma\} \right)$ and $\tilde{Z} := P_{Z, n} \cup \left(\bigcup_{\tau \in X^{(i)} : i < n} \{\bigcap_{\sigma \in X^{(n)} : \tau \subseteq \sigma} \tau_\sigma | \tau_\sigma \in P_{Z, \tau}^\sigma\} \right)$. Moreover for every $\tau \in \tilde{Y} \cup \tilde{Z}$ choose some $\sigma \in X^{(n)}$ with $\tau \subseteq \sigma$ and let $\psi_\tau := \varphi_\sigma|_\tau$. Note that by construction $(\tilde{Y}, |Y \cap X|)$ and $(\tilde{Z}, |Z \cap X|)$ with structure maps ψ_τ , $\tau \in \tilde{X}$ or $\tau \in \tilde{Z}$ respectively and weight functions $\omega_{\tilde{Y}}$ and $\omega_{\tilde{Z}}$ induced by $Y \cap X$ and $Z \cap X$ are refinements of $Y \cap X$ and $Z \cap X$ (we need here that $R_{Y \cap X}^\sigma$ and $R_{Z \cap X}^\sigma$ were usual polyhedral complexes in \mathbb{R}^{n_σ}). Thus we can endow them with the tropical structures inherited from $Y \cap X$ and $Z \cap X$ respectively (cf. construction 5.6). As $(\tilde{X} \cup \tilde{Y}, |Y \cap X| \cup |Z \cap X|)$ is a polyhedral complex

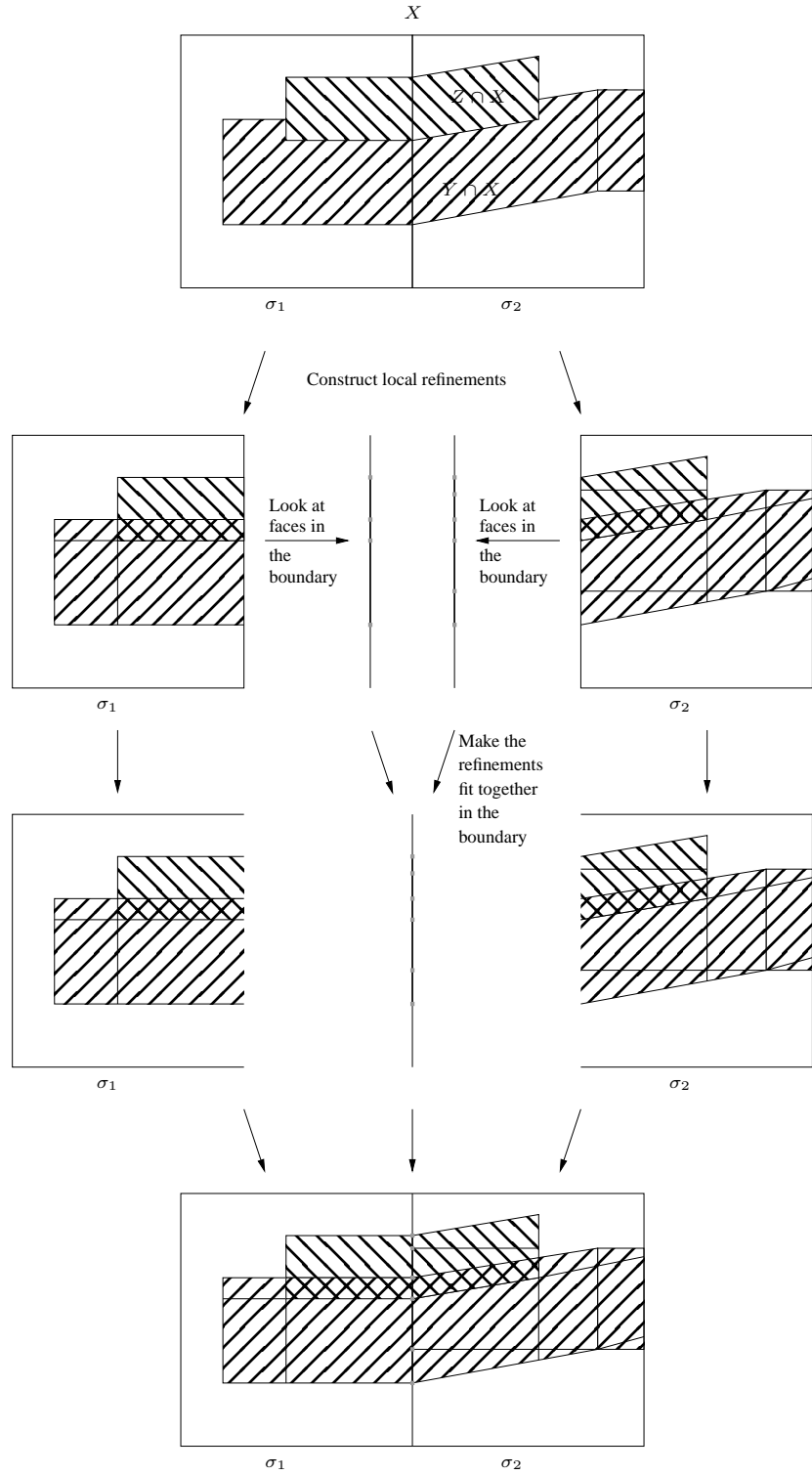

An illustration of the process described in construction 5.14.

now, we can form

$$((P, |P|), \omega_P) := ((\tilde{X} \cup \tilde{Y}, |Y \cap X| \cup |Z \cap X|), \omega_P),$$

where $\omega_P(\sigma) := \omega_{\tilde{Y}}(\sigma) + \omega_{\tilde{Z}}(\sigma)$ for all $\sigma \in P^{(k)}$ (we set $\omega_{\square}(\sigma) := 0$ for $\sigma \notin \square$, $\square \in \{\tilde{Y}, \tilde{Z}\}$). Recall that the tropical structures on \tilde{Y} and \tilde{Z} are inherited from $Y \cap X$ and $Z \cap X$ and are thus compatible with the tropical structure on X . Thus $\Phi_{\sigma}^X(S_{\sigma}^P) \subseteq |F_{\sigma}^X|$ with weights induced from P is an open fan (the corresponding complete tropical fan is just the sum of the fans coming from \tilde{Y} and \tilde{Z}). Thus we can set $\tilde{\Phi}_{\sigma} := \Phi_{\sigma}^X|_{S_{\sigma}^P} : S_{\sigma}^P \xrightarrow{\sim} \Phi_{\sigma}^X(S_{\sigma}^P)$ and can hence define the sum $D_1 + D_2$ to be

$$D_1 + D_2 := \left[\left(((P, |P|), \omega_P), \{\tilde{\Phi}_{\sigma}\} \right) \right].$$

Note that the class $\left[\left(((P, |P|), \omega_P), \{\tilde{\Phi}_{\sigma}\} \right) \right]$ is independent of the choices we made, i.e. the sum $D_1 + D_2$ is well-defined.

Lemma 5.15. *Let $C \in Z_n$ be a tropical cycle. The set $Z_k(C)$ together with the operation “+” from construction 5.14 forms an abelian group.*

Proof. The class of the empty complex $0 = [\emptyset]$ is the neutral element of this operation and $\left[((Y, |Y|), -\omega_Y) \right]$ is the inverse element of $\left[((Y, |Y|), \omega_Y) \right] \in Z_k(C)$. \square

6. CARTIER DIVISORS AND THEIR ASSOCIATED WEIL DIVISORS

Definition 6.1 (Rational functions and Cartier divisors). Let C be an abstract k -cycle and let U be an open set in $|C|$. A (non-zero) rational function on U is a continuous function $\varphi : U \rightarrow \mathbb{R}$ such that there exists a representative $\left(((X, |X|, \{m_{\sigma}\}_{\sigma \in X}), \omega_X), \{M_{\sigma}\}_{\sigma \in X} \right)$ of C such that for each face $\sigma \in X$ the map $\varphi \circ m_{\sigma}^{-1}$ is locally integer affine linear (where defined). The set of all non-zero rational functions on U is denoted by $\mathcal{K}_C^*(U)$ or just $\mathcal{K}^*(U)$.

If additionally for each face $\sigma \in X$ the map $\varphi \circ M_{\sigma}^{-1}$ is locally integer affine linear (where defined), φ is called *regular invertible*. The set of all regular invertible functions on U is denoted by $\mathcal{O}_C^*(U)$ or just $\mathcal{O}^*(U)$.

A representative of a Cartier divisor on C is a finite set $\{(U_1, \varphi_1), \dots, (U_l, \varphi_l)\}$, where $\{U_i\}$ is an open covering of $|C|$ and $\varphi_i \in \mathcal{K}^*(U_i)$ are rational functions on U_i that only differ in regular invertible functions on the overlaps, in other words, for all $i \neq j$ we have $\varphi_i|_{U_i \cap U_j} - \varphi_j|_{U_i \cap U_j} \in \mathcal{O}^*(U_i \cap U_j)$.

We define the sum of two representatives by $\{(U_i, \varphi_i)\} + \{(V_j, \psi_j)\} = \{(U_i \cap V_j, \varphi_i + \psi_j)\}$, which obviously fulfills again the condition on the overlaps.

We call two representatives $\{(U_i, \varphi_i)\}, \{(V_j, \psi_j)\}$ *equivalent* if $\varphi_i - \psi_j$ is regular invertible (where defined) for all i, j , i.e. $\{(U_i, \varphi_i)\} - \{(V_j, \psi_j)\} = \{(W_k, \gamma_k)\}$ with $\gamma_k \in \mathcal{O}^*(W_k)$. Obviously, “+” induces a group structure on the set of equivalence classes of representatives with the neutral element $\{|C|, c_0\}$, where c_0 is the constant zero function. This group is denoted by $\text{Div}(C)$ and its elements are called *Cartier divisors on C* .

Example 6.2. Let us give an example of a Cartier divisor which is not globally defined by a rational function: As abstract cycle C we take the elliptic curve $[X_2]$ from example 5.5 (the brackets resemble the fact that, to be precise, we take the equivalence class of the polyhedral complex X_2 with respect to refinements). By α_1, α_2 we denote the two vertices in X_2 . W.l.o.g. we can assume that the maps M_{α_i} map the points α_i exactly to $0 \in \mathbb{R}$. Of course, the stars $S_{\alpha_1}, S_{\alpha_2}$ cover our whole space $|C| = |X_2|$. So we can define the Cartier

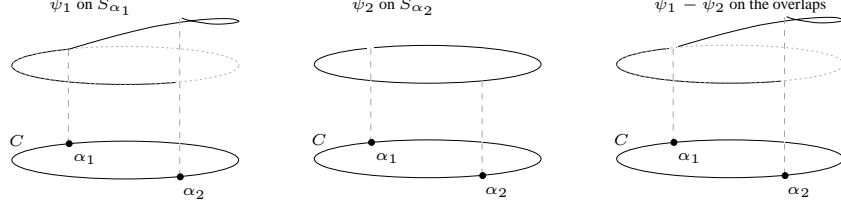
The Cartier divisor φ defined in example 6.2.

divisor $\varphi := [\{(S_{\alpha_1}, \psi_1), (S_{\alpha_2}, \psi_2)\}]$, where $\psi_1 := \max(0, x) \circ M_{\alpha_1}$ and $\psi_2 := c_0 \circ M_{\alpha_2}$ with c_0 the constant zero function. Let us check the condition on the overlaps: On one open half of our curve the two functions coincide, whereas on the other open half they differ by a linear function. So we constructed an Cartier divisor which can not be globally defined by one rational function (as ψ_1 can not be completed to a continuous function on $|C|$).

Remark 6.3 (Restrictions to subcycles). Note that, as in the affine case (see remark 3.2), we can restrict a non-zero rational function $\varphi \in \mathcal{K}_C^*(U)$ to an arbitrary subcycle $D \subseteq C$, i.e. $\varphi|_{U \cap |D|} \in \mathcal{K}_D^*(U \cap |D|)$. It is also true that a regular invertible function $\varphi \in \mathcal{O}_C^*(U)$ restricted to D is again regular invertible, i.e. $\varphi|_{U \cap |D|} \in \mathcal{O}_D^*(U \cap |D|)$. Hence we can also restrict a Cartier divisor $[\{(U_i, \varphi_i)\}] \in \text{Div}(C)$ to D by setting $[\{(U_i, \varphi_i)\}]|_D := [\{(U_i \cap |D|, \varphi_i|_{U_i \cap |D|})\}] \in \text{Div}(D)$. Let us also stress again that we still require our objects to be defined everywhere (on a given open subset U). This causes problems like for example in remark 8.6.

Construction 6.4 (Intersection products). Let C be an abstract k -cycle and $\varphi = [\{(U_i, \varphi_i)\}] \in \text{Div}(C)$ a Cartier divisor on C . By definition 6.1 and lemma 5.11, there exists a representative $((X, |X|, \{m_\sigma\}_{\sigma \in X}, \omega_X), \{M_\sigma\}_{\sigma \in X})$ of C such that for all i and $\sigma \in X$ the map $\varphi_i \circ m_\sigma^{-1}$ is locally integer affine linear (where defined). We can also assume that $X = X^*$, as our functions are defined on $|C| = |X^*|$ at the most. We would like to define the intersection product $\varphi \cdot C$ to be

$$\left[\left((Y, |Y|, \{m_\sigma\}_{\sigma \in Y}, \omega_{X, \varphi}), \{M_\sigma|_{S_\sigma^Y} : S_\sigma^Y \rightarrow |F_\sigma^Y|\}_{\sigma \in Y} \right) \right],$$

where

$$Y := \bigcup_{i=0}^{k-1} X^{(i)}, \quad |Y| := \bigcup_{\sigma \in Y} \sigma, \quad S_\sigma^Y = \bigcup_{\substack{\sigma' \in Y \\ \sigma \subseteq \sigma'}} (\sigma')^{r_i}, \quad F_\sigma^Y := \bigcup_{i=0}^{k-1} F_\sigma^{(i)}$$

and $\omega_{X, \varphi}$ is an appropriate weight function. So it remains to construct $\omega_{X, \varphi}(\tau)$ for $\tau \in X^{(k-1)}$.

First, we do this pointwise, i.e. we construct $\omega_{X, \varphi}(p)$ for $p \in (\tau)^{r_i}$. Given a $p \in (\tau)^{r_i}$, we pick an i with $p \in U_i$. Let V be the connected component of $M_\tau(U_i \cap S_\tau)$ containing $M_\tau(p)$. Then the function $\varphi_i \circ M_\tau^{-1}|_V$ can be uniquely extended to a rational function $\tilde{\varphi}_i \in \mathcal{K}^*([\tilde{F}_\tau, \omega_{\tilde{F}_\tau}])$, where $(\tilde{F}_\tau, \omega_{\tilde{F}_\tau})$ is the tropical fan generated by the open fan $(F_\tau, \omega_{F_\tau})$. So, in the affine case, we can compute $\omega_{\tilde{F}_\tau, \tilde{\varphi}_i}(\mathbb{R} \cdot M_\tau(\tau))$ (see construction 3.3 and definition 3.4) and define $\omega_{X, \varphi}(p) := \omega_{\tilde{F}_\tau, \tilde{\varphi}_i}(\mathbb{R} \cdot M_\tau(\tau))$.

This definition is well-defined, namely if we pick another j with $p \in U_j$ and denote by V' the connected component of $M_\tau(U_j \cap S_\tau)$ containing $M_\tau(p)$, we know by definition of a Cartier divisor that $\varphi_i \circ M_\tau^{-1}|_{V \cap V'} - \varphi_j \circ M_\tau^{-1}|_{V \cap V'}$ is affine linear, hence $\tilde{\varphi}_i - \tilde{\varphi}_j$ is

affine linear. By remark 3.6 we get $\omega_{\tilde{F}_\tau, \tilde{\varphi}_i}(\mathbb{R} \cdot M_\tau(\tau)) = \omega_{\tilde{F}_\tau, \tilde{\varphi}_j}(\mathbb{R} \cdot M_\tau(\tau))$.

The same argument shows that our definition does not depend on the choice of a representative $\{(U_i, \varphi_i)\}$ of φ .

But as $(\tau)^{r_i}$ is connected, the continuous function $\omega_{X, \varphi} : (\tau)^{r_i} \rightarrow \mathbb{Z}$ must be constant. Hence, we define $\omega_{X, \varphi}(\tau) := \omega_{X, \varphi}(p)$ for some $p \in (\tau)^{r_i}$. With this weight function

$$\left(\left((Y, |Y|, \{m_\sigma\}_{\sigma \in Y}), \omega_{X, \varphi}, \{M_\sigma|_{S_\sigma^Y}\}_{\sigma \in Y} \right) \right)$$

is a tropical polyhedral complex.

Let us now check if the equivalence class of this complex is independent of the choice of representatives of C . Let therefore $((X', |X'|, \{m_{\sigma'}\}_{\sigma' \in X'}), \omega_{X'})$ be a refinement of $((X, |X|, \{m_\sigma\}_{\sigma \in X}), \omega_X)$ (we can again assume $X' = X'^*$). Then, for each $\sigma' \in X'$, the map $M_{C_{X', X}(\sigma')} \circ M_{\sigma'}^{-1}$ embeds $F_{\sigma'}$ into a refinement of $F_{C_{X', X}(\sigma')}$. Applying the affine statement here (see remark 3.5), we deduce that for each $\tau' \in X'^{(k-1)}$ it holds $\omega_{X', \varphi}(\tau') = 0$ (if $\dim C_{X', X}(\tau') = k$) or $\omega_{X', \varphi}(\tau') = \omega_{X, \varphi}(C_{X', X}(\tau'))$ (if $\dim C_{X', X}(\tau') = k - 1$).

Definition 6.5 (Intersection products). Let C be an abstract k -cycle and $\varphi = [\{(U_i, \varphi_i)\}] \in \text{Div}(C)$ a Cartier divisor on C . Let furthermore $((X, |X|, \{m_\sigma\}_{\sigma \in X}), \omega_X)$ be a representative of C such that $|X| = |C|$ and for all i and $\sigma \in X$ the map $\varphi_i \circ m_\sigma^{-1}$ is locally integer affine linear (where defined). The associated Weil divisor $\text{div}(\varphi) = \varphi \cdot C$ is defined to be

$$\left[\left(\left((Y := \bigcup_{i=0}^{k-1} X^{(i)}, \bigcup_{\sigma \in Y} \sigma, \{m_\sigma\}_{\sigma \in Y}), \omega_{X, \varphi}, \{M_\sigma|_{S_\sigma^Y}\}_{\sigma \in Y} \right) \right) \right] \in Z_{k-1}(C),$$

where $S_\sigma^Y = \bigcup_{\substack{\sigma' \in Y \\ \sigma \subseteq \sigma'}} (\sigma')^{r_i}$ and $\omega_{X, \varphi}$ is the weight function constructed in construction 6.4.

Let $D \in Z_l(C)$ be an arbitrary subcycle of C of dimension l . We define the *intersection product of φ with D* to be $\varphi \cdot D := \varphi|_D \cdot D \in Z_{l-1}(C)$.

Example 6.6. Let us compute the Weil divisor associated to our Cartier divisor φ on the elliptic curve C constructed in example 6.2. In fact, there is nothing to compute: One can see immediately from the picture that $\text{div}(\varphi)$ is just the vertex α_1 with multiplicity 1 (the multiplicity of α_2 is 0 as in order to compute it, one has to use the constant function ψ_2). Let us stress that this single point can not be obtained as the Weil divisor of a (global) rational function, as all such divisors must have “degree 0” (this is defined precisely and proven in remark 8.4 and lemma 8.3).

Proposition 6.7 (Commutativity). Let $\varphi, \psi \in \text{Div}(C)$ be two Cartier divisors on C . Then $\psi \cdot (\varphi \cdot C) = \varphi \cdot (\psi \cdot C)$.

Proof. Say $\varphi = [\{(U_i, \varphi_i)\}]$ and $\psi = [\{(V_j, \psi_j)\}]$. Using lemma 5.11 we find a representative $((X, |X|, \{m_\sigma\}_{\sigma \in X}), \omega_X)$ of C such that $|X| = |C|$ and for all i, j and $\sigma \in X$ the maps $\varphi_i \circ m_\sigma^{-1}$ and $\psi_j \circ m_\sigma^{-1}$ are locally integer affine linear (where defined). For $\theta \in X^{(k-2)}$, $p \in (\theta)^{r_i}$ and i, j with $p \in U_i \cap V_j$ we get (using notations from construction 6.4) $\omega_{X, \varphi, \psi}(\theta) = \omega_{X, \varphi, \psi}(p) = \omega_{\tilde{F}_\theta, \tilde{\varphi}_i, \tilde{\psi}_j}(\mathbb{R} \cdot M_\theta(\theta))$ and similarly $\omega_{X, \psi, \varphi}(\theta) = \omega_{\tilde{F}_\theta, \tilde{\psi}_j, \tilde{\varphi}_i}(\mathbb{R} \cdot M_\theta(\theta))$. Using the corresponding statement in the affine case now (see proposition 3.7 (b)), we deduce that the two weight functions are equal which proves the claim. \square

7. PUSH-FORWARD OF TROPICAL CYCLES AND PULL-BACK OF CARTIER DIVISORS

Definition 7.1 (Morphisms of tropical cycles). Let $C \in Z_n$ and $D \in Z_m$ be two tropical cycles. A *morphism* $f : C \rightarrow D$ of tropical cycles is a continuous map $f : |C| \rightarrow |D|$ with the following property: There exist reduced representatives $((X, |X|), \omega_X, \{\Phi_\sigma\})$ of C and $((Y, |Y|), \omega_Y, \{\Psi_\tau\})$ of D such that

- (a) for every polyhedron $\sigma \in X$ there exists a polyhedron $\tilde{\sigma} \in Y$ with $f(\sigma) \subseteq \tilde{\sigma}$,
- (b) for every pair $\sigma, \tilde{\sigma}$ from (a) the map $\Psi_{\tilde{\sigma}} \circ f \circ \Phi_\sigma^{-1} : |F_\sigma^X| \rightarrow |F_{\tilde{\sigma}}^Y|$ induces a morphism of fans $\tilde{F}_\sigma^X \rightarrow \tilde{F}_{\tilde{\sigma}}^Y$ (cf. definition 4.1), where \tilde{F}_σ^X and $\tilde{F}_{\tilde{\sigma}}^Y$ are the tropical fans associated to F_σ^X and $F_{\tilde{\sigma}}^Y$ respectively (cf. definition 5.3).

First of all we want to show that the restriction of a morphism to a subcycle is again a morphism:

Lemma 7.2. *Let $C \in Z_n$ and $D \in Z_m$ be two cycles, $f : C \rightarrow D$ a morphism and $E \in Z_k(C)$ a subcycle of C . Then the map $f|_{|E|} : |E| \rightarrow |D|$ induces a morphism of tropical cycles $f|_E : E \rightarrow D$.*

Proof. By definition of morphism there exist reduced representatives $((X_1, |X_1|), \omega_{X_1})$ of C and $((Y, |Y|), \omega_Y)$ of D such that properties (a) and (b) in definition 7.1 are fulfilled. By definition of subcycle there exist reduced representatives $((Z_1, |Z_1|), \omega_{Z_1})$ of E and $((X_2, |X_2|), \omega_{X_2})$ of C such that properties (a) and (b) in definition 5.12 are fulfilled, i.e. such that $(Z_1, |Z_1|) \trianglelefteq (X_2, |X_2|)$ and the tropical structures on Z_1 and X_2 agree. As “ \sim ” is an equivalence relation there exists a common refinement $((X, |X|), \omega_X)$ of $((X_1, |X_1|), \omega_{X_1})$ and $((X_2, |X_2|), \omega_{X_2})$ which we may assume to be reduced. Applying construction 5.10 to Z_1 and X we obtain a refinement $((Z, |Z|), \omega_Z) := ((Z_1 \cap X, |Z_1 \cap X|), \omega_{Z_1 \cap X})$ of $((Z_1, |Z_1|), \omega_{Z_1})$ such that $(Z, |Z|) \trianglelefteq (X, |X|)$ and the tropical structures on Z and X agree. Thus properties (a) and (b) of definition 7.1 are fulfilled by Z and Y and the restricted map $f|_{|E|} : |E| \rightarrow |D|$ gives us a morphism $f|_E : E \rightarrow D$. \square

If we are given a morphism and a tropical cycle the following construction shows how to build the push-forward cycle of the given one along our morphism:

Construction 7.3 (Push-forward of tropical cycles). Let $C \in Z_n$ and $D \in Z_m$ be two cycles and let $f : C \rightarrow D$ be a morphism. Let $((X, |X|), \{\varphi_\sigma\}, \omega_X, \{\Phi_\sigma\})$ and $((Y, |Y|), \{\psi_\sigma\}, \omega_Y, \{\Psi_\tau\})$ be representatives of C and D fulfilling properties (a) and (b) of definition 7.1. Consider the collection of polyhedra

$$Z := \{f(\sigma) | \sigma \in X \text{ contained in a maximal polyhedron of } X \text{ on which } f \text{ is injective}\}.$$

In general Z is not a polyhedral complex. We resolve this by subdividing the polyhedra in Z and refining X accordingly:

Fix some polyhedron $\tilde{\sigma} \in Y^{(m)}$ and let $\tau_1, \dots, \tau_r \in Z$ be all polyhedra that are contained in $\tilde{\sigma}$. Property (b) of definition 7.1 implies that $\{\psi_{\tilde{\sigma}}(\tau_i) | i = 1, \dots, r\}$ is a set of rational polyhedra in $\mathbb{R}^{n_{\tilde{\sigma}}}$. Like in remark and definition 5.13 let $\{g_i(x) \leq b_i | i = 1, \dots, N\}$, $g_i \in \text{Hom}(\mathbb{Z}^{n_{\tilde{\sigma}}}, \mathbb{Z})$, $b_i \in \mathbb{R}$ be all inequalities occurring in the description of all polyhedra in $\{\psi_{\tilde{\sigma}}(\tau_i) | i = 1, \dots, r\}$ and let

$$\begin{aligned} R_{\tilde{\sigma}} &:= \{\psi_{\tilde{\sigma}}(\tau_i) | i = 1, \dots, r\} \cap H_{G_1, b_1} \cap \dots \cap H_{G_N, b_N}, \\ P_{\tilde{\sigma}} &:= \{\psi_{\tilde{\sigma}}^{-1}(\tau) | \tau \in R_{\tilde{\sigma}}\}. \end{aligned}$$

Like in construction 5.14 $P_{\tilde{\sigma}}$ can be seen as a kind of local refinement of Z . But here again taking the union over all maximal polyhedra $\tilde{\sigma} \in Y^{(m)}$ does in general not lead to a global refinement as there may be overlaps between polyhedra coming from different $\tilde{\sigma}$. We fix this as follows (cf. 5.14): For $\tilde{\sigma} \in Y^{(m)}$ and $\tilde{\tau} \in \bigcup_{i=0}^{m-1} Y^{(i)}$ let $P_{\tilde{Z}, \tilde{\tau}}^{\tilde{\sigma}} := \{\varrho \in P_{\tilde{\sigma}} \mid \tilde{\tau} \text{ is the inclusion minimal polyhedron of } Y \text{ containing } \varrho\}$ and $P_{Z, m} := \bigcup_{\tilde{\sigma} \in Y^{(m)}} \{\varrho \in P_{\tilde{\sigma}} \mid \exists \tilde{\tau} \in Y^{(m-1)} : \varrho \subseteq \tilde{\tau}\}$. Then $\tilde{Z} := P_{Z, m} \cup \left(\bigcup_{\tilde{\tau} \in Y^{(i)} : i < m} \{\bigcap_{\tilde{\sigma} \in Y^{(m)} : \tilde{\tau} \subseteq \tilde{\sigma}} \tau_{\tilde{\sigma}} \mid \tau_{\tilde{\sigma}} \in P_{\tilde{Z}, \tilde{\tau}}^{\tilde{\sigma}}\} \right)$ is the set of polyhedra (without any overlaps now) that shall induce our wanted refinement of X : Let $T := \{\sigma \in X^{(n)} \mid f \text{ is injective on } \sigma\}$, $Q_0 := \{\tau \in X \mid \exists \sigma \in T : \tau \subseteq \sigma\}$ and $Q_1 := \left(\bigcup_{\sigma \in T} \{(f|_{\sigma})^{-1}(\tau) \mid \tau \in \tilde{Z}, \tau \subseteq f(\sigma)\} \right)$. Then define $\tilde{X} := Q_0 \cup Q_1$.

Let $\tau \in Q_1$ and choose $\sigma \in T$ with $\tau \subseteq \sigma$. Property (b) of definition 7.1 implies that $\psi_{\tilde{\sigma}} \circ f \circ \varphi_{\sigma}^{-1}$ is integer affine linear where defined. Hence $\varphi_{\sigma}(\tau)$ is a rational polyhedron in $\mathbb{R}^{n_{\sigma}}$. Denote by $H_{\sigma, \tau}$ the smallest affine subspace of $\mathbb{R}^{n_{\sigma}}$ containing $\varphi_{\sigma}(\tau)$. We can consider $\varrho_{\tau} := \varphi_{\sigma}|_{\tau}$ to be a map $\varrho_{\tau} : \tau \rightarrow H_{\sigma, \tau} \cong \mathbb{R}^{n_{\tau}}$. Note that by construction $(\tilde{X}, |X|, \{\varrho_{\tau}\})$ is a polyhedral complex. We endow it with the weight function $\omega_{\tilde{X}}$ and tropical structure $\{\Phi_{\tau}^{\tilde{X}}\}$ induced by X . Now we are able to define

$f_*X := \{f(\sigma) \mid \sigma \in \tilde{X} \text{ contained in a maximal polyhedron of } \tilde{X} \text{ on which } f \text{ is injective}\}$ and $|f_*X| := \bigcup_{\tau \in f_*X} \tau$. For every polyhedron $\tau \in f_*X$ let $\sigma_{\tau} \in Y$ be the inclusion-minimal polyhedron containing τ . Then define $\vartheta_{\tau} := \psi_{\sigma_{\tau}}|_{\tau} : \tau \rightarrow H_{\sigma_{\tau}, \tau} \cong \mathbb{R}^{n_{\tau}}$, where $H_{\sigma_{\tau}, \tau} \subseteq \mathbb{R}^{n_{\sigma_{\tau}}}$ is the smallest affine subspace containing the rational polyhedron $\psi_{\sigma_{\tau}}(\tau) \in \tilde{Z}$. Note that this makes $(f_*X, |f_*X|, \{\vartheta_{\tau}\})$ into a polyhedral complex. Moreover note that property (b) of definition 7.1 still holds for \tilde{X} and Y . Hence we can assign weights and tropical fans to f_*X as follows: Let $\sigma \in f_*X$, let $\tilde{\sigma} \in Y$ be the inclusion-minimal polyhedron containing it and let $\tau_1, \dots, \tau_r \in \tilde{X}$ be all polyhedra with $f(\tau_i) = \sigma$ that are contained in a maximal polyhedron of \tilde{X} on which f is injective. Then let $\Psi_{\tilde{\sigma}}(S_{\tilde{\sigma}}) = F_{\tilde{\sigma}}^Y$ and $\Phi_{\tau_i}^{\tilde{X}}(S_{\tau_i}) = F_{\tau_i}^{\tilde{X}}$ respectively be the corresponding open fans and $\tilde{F}_{\tilde{\sigma}}^Y, \tilde{F}_{\tau_i}^{\tilde{X}}$ be the associated tropical fans. Property (b) of definition 7.1 implies that $f_*\tilde{F}_{\tau_i}^{\tilde{X}} \subseteq |\tilde{F}_{\tilde{\sigma}}^Y|$ is again a tropical fan (note that we do not need to refine $\tilde{F}_{\tau_i}^{\tilde{X}}$ to construct this push-forward). Thus we can define

$$\left(\tilde{F}_{\sigma}^{f_*X}, \omega_{\tilde{F}_{\sigma}^{f_*X}} \right) := \left(\bigcup_{i=1}^r f_*\tilde{F}_{\tau_i}^{\tilde{X}}, \sum_{i=1}^r \omega_{f_*\tilde{F}_{\tau_i}^{\tilde{X}}} \right) \quad \text{and} \quad F_{\sigma}^{f_*X} := \tilde{F}_{\sigma}^{f_*X} \cap \Psi_{\tilde{\sigma}}(S_{\tilde{\sigma}})$$

(here again we assume that $\omega_{f_*\tilde{F}_{\tau_i}^{\tilde{X}}}(\tau) = 0$ if $\tau \notin f_*\tilde{F}_{\tau_i}^{\tilde{X}}$). Moreover we define

$$\Theta_{\sigma} := \Psi_{\tilde{\sigma}}|_{S_{\sigma}} : S_{\sigma} \rightarrow |F_{\sigma}^{f_*X}|.$$

Then the map $\Theta_{\sigma}, \sigma \in f_*X$ is 1:1 on polyhedra and we can endow the maximal polyhedra of f_*X with weights $\omega_{f_*X}(\cdot)$ coming from $F_{\sigma}^{f_*X}$ in this way. These weights are obviously well-defined by property (c) of the tropical polyhedral complex Y (cf. definition 5.4) and the maps Θ_{σ} for different $\sigma \in f_*X$ are obviously compatible. Hence we can define

$$f_*C := \left[\left(((f_*X, |f_*X|, \{\vartheta_{\tau}\}), \omega_{f_*X}), \{\Theta_{\tau}\} \right) \right] \in Z_n(D).$$

Note that the class $[(((f_*X, |f_*X|, \{\vartheta_{\tau}\}), \omega_{f_*X}), \{\Theta_{\tau}\})]$ is independent of the choices we made. Thus construction 7.3 immediately leads to the following

Corollary 7.4 (Push-forward of tropical cycles). *Let $C \in Z_n$ and $D \in Z_m$ be two cycles and let $f : C \rightarrow D$ be a morphism. Then for all k there is a well-defined and \mathbb{Z} -linear map*

$$Z_k(C) \longrightarrow Z_k(D) : E \longmapsto f_*E := (f|_E)_*E.$$

Proof. The linearity can be proven similar to the affine case (cf. proposition 4.6). \square

Our next aim is to define the pull-back of Cartier divisors. But first we need the following

Lemma 7.5. *Let $C \in Z_n$ and $D \in Z_m$ be two tropical cycles and let $f : C \rightarrow D$ be a morphism. By definition there exist reduced representatives $((X, |X|, \{\varphi_\sigma\}, \omega_X), \{\Phi_\sigma\})$ of C and $((Y, |Y|, \{\psi_\tau\}, \omega_Y), \{\Psi_\tau\})$ of D such that properties (a) and (b) in definition 7.1 are fulfilled. Let $((Y_1, |Y_1|, \{\psi'_{\tau'}\}, \omega_{Y_1}), \{\Psi'_{\tau'}\})$ be a refinement of Y . Then there is a refinement $((X_1, |X_1|, \{\varphi'_{\sigma'}\}, \omega_{X_1}), \{\Phi'_{\sigma'}\})$ of X such that properties (a) and (b) of definition 7.1 are fulfilled for X_1 and Y_1 .*

Proof. Let $X_1 := \{\sigma \cap f^{-1}(\tau) \mid \sigma \in X, \tau \in Y_1\}$. By property (b) of definition 7.1 all $\varphi_\sigma(\sigma \cap f^{-1}(\tau))$ are rational polyhedra in \mathbb{R}^{n_σ} . For every $\sigma' \in X_1$ choose $\sigma \in X$ such that $\sigma' = \sigma \cap f^{-1}(\tau)$ for some $\tau \in Y_1$. Then we can define $\varphi'_{\sigma'} := \varphi_\sigma|_{\sigma'} : \sigma' \rightarrow H_{\sigma, \sigma'} \cong \mathbb{R}^{n_{\sigma'}}$, where $H_{\sigma, \sigma'}$ is the smallest affine subspace of \mathbb{R}^{n_σ} containing $\varphi_\sigma(\sigma')$. Moreover let $|X_1| := |X|$. Note that with these settings $(X_1, |X_1|, \{\varphi'_{\sigma'}\})$ is a polyhedral complex. We can endow it with the weight function ω_{X_1} and the tropical structure $\{\Phi'_{\sigma'}\}$ induced by X . Together with Y_1 the tropical polyhedral complex $((X_1, |X_1|, \{\varphi'_{\sigma'}\}, \omega_{X_1}), \{\Phi'_{\sigma'}\})$ fulfills the requirements (a) and (b) of definition 7.1. \square

Proposition 7.6 (Pull-back of Cartier divisors). *Let $C \in Z_n$ and $D \in Z_m$ be tropical cycles and let $f : C \rightarrow D$ be a morphism. Then there is a well-defined and \mathbb{Z} -linear map*

$$\text{Div}(D) \longrightarrow \text{Div}(C) : [\{(U_i, h_i)\}] \longmapsto f^*[\{(U_i, h_i)\}] := [\{(f^{-1}(U_i), h_i \circ f)\}].$$

Proof. We have to show that $h \circ f \in \mathcal{K}_C^*(f^{-1}(U))$ for $h \in \mathcal{K}_D^*(U)$ and that $h \circ f \in \mathcal{O}_C^*(f^{-1}(U))$ for $h \in \mathcal{O}_D^*(U)$. Then the rest is obvious.

So let $h \in \mathcal{K}_D^*(U)$. Then there exists a representative $((Y, |Y|, \{\psi_\sigma\}, \omega_Y), \{\Psi_\tau\})$ of D such that for every polyhedron $\sigma \in Y$ the map $h \circ \psi_\sigma^{-1}$ is locally integer affine linear. Moreover, since f is a morphism there exist representatives $((X, |X|, \{\varphi_\sigma\}, \omega_X), \{\Phi_\tau\})$ of C and $((Y', |Y'|, \{\psi'_{\sigma'}\}, \omega_{Y'}), \{\Psi'_{\tau'}\})$ of D such that properties (a) and (b) of definition 7.1 are fulfilled, i.e. $f(\sigma) \subseteq \tilde{\sigma} \in Y'$ for all $\sigma \in X$ and the maps $\Psi_{\tilde{\sigma}} \circ f \circ \Phi_\sigma^{-1}$ induce morphisms of fans. By lemma 7.5 we may assume that $Y = Y'$. Now let $\sigma \in X$ and choose some $\tilde{\sigma} \in Y$ such that $f(\sigma) \subseteq \tilde{\sigma}$. Property (b) of definition 7.1 implies that $\psi_{\tilde{\sigma}} \circ f \circ \varphi_\sigma^{-1}$ and $\Psi_{\tilde{\sigma}} \circ f \circ \Phi_\sigma^{-1}$ are integer affine linear. Thus $h \circ f \circ \varphi_\sigma^{-1} = (h \circ \psi_{\tilde{\sigma}}^{-1}) \circ (\psi_{\tilde{\sigma}} \circ f \circ \varphi_\sigma^{-1})$ is locally integer affine linear and $h \circ f \in \mathcal{K}_C^*(f^{-1}(U))$. If additionally $h \circ \Psi_{\tilde{\sigma}}^{-1}$ is locally integer affine linear then so is $h \circ f \circ \Phi_\sigma^{-1} = (h \circ \Psi_{\tilde{\sigma}}^{-1}) \circ (\Psi_{\tilde{\sigma}} \circ f \circ \Phi_\sigma^{-1})$. Hence $h \circ f \in \mathcal{O}_C^*(f^{-1}(U))$ for $h \in \mathcal{O}_D^*(U)$. \square

Our last step in this chapter is to state the analogon of the projection formula from 4.8:

Proposition 7.7 (Projection formula). *Let $C \in Z_n$ and $D \in Z_m$ be two cycles and $f : C \rightarrow D$ be a morphism. Let $E \in Z_k(C)$ be a subcycle of C and $d \in \text{Div}(D)$ be a Cartier divisor. Then the following holds:*

$$d \cdot (f_*C) = f_*(f^*d \cdot C) \in Z_{k-1}(D).$$

Proof. The claim follows from the constructions of f_*C and f^*d , from definition 6.5 and proposition 4.8. \square

8. RATIONAL EQUIVALENCE

We will now make some first steps in establishing a concept of rational equivalence.

We fix an abstract tropical cycle A as ambient space and an arbitrary subgroup $R \subseteq \text{Div}(A)$ of the group of Cartier divisors on A . We define the *Picard group* as the quotient group $\text{Pic}(A) := \text{Div}(A)/R$. Let $R_k \subseteq Z_k(A)$ denote the group generated by $\{\varphi \cdot C \mid \varphi \in R, C \in Z_{k+1}(A)\}$, i.e. by all k -dimensional cycles obtained by intersecting a Cartier divisor from R with an arbitrary $(k+1)$ -dimensional cycle. We define the *k -th Chow group* to be $A_k(A) := Z_k(A)/R_k$.

Corollary 8.1 (Intersection products modulo rational equivalence). *The map*

$$\begin{aligned} \cdot : \text{Pic}(A) \times A_k(A) &\rightarrow A_{k-1}(A), \\ ([\varphi], [D]) &\mapsto [\varphi \cdot D] \end{aligned}$$

is well-defined and bilinear.

Proof. By definition, for each $\varphi \in R, D \in Z_k(A)$ we have $\varphi \cdot D \in R_{k-1}$. Let furthermore $\varphi \cdot C$ be an element in R_k (where $\varphi \in R, C \in Z_k(A)$). Then it follows from proposition 3.7 b) that for arbitrary $\psi \in \text{Div}(A)$ we get $\psi \cdot (\varphi \cdot C) = \varphi \cdot (\psi \cdot C) \in R_{k-1}$. The claim follows from the bilinearity of the intersection product. \square

So far, our intersection theory takes place (at least locally) in \mathbb{R}^n , which can be considered as the n -dimensional tropical algebraic torus. Especially, if we generated rational equivalence by all rational functions on A , the resulting Chow groups and intersection products would be useless in enumerative geometry: As in the classical case, the divisor of a rational function might have components in the “boundary” of some compactification of the “affine” variety \mathbb{R}^n . Therefore, in the following we restrict the functions that generate rational equivalence to those “whose divisor in any torical compactification has no components in the boundary”.

Definition 8.2 (Rational equivalence generated by bounded functions). Let A be an abstract tropical cycle and $R(A) := \{[|A|, \varphi] \mid \varphi \text{ bounded}\}$ be the group of all Cartier divisors globally given by a bounded rational function. We define the *Picard group* $\text{Pic}(A) := \text{Div}(A)/R(A)$ and the *Chow groups* $A_k(A)$ as above. We call two Cartier divisors (two k -dimensional subcycles resp.) *rationally equivalent*, if their classes in $\text{Pic}(A)$ ($A_k(A)$ resp.) are the same.

Let us prove that we do not divide out too much for applications in enumerative geometry.

Lemma 8.3. *Let C be an one-dimensional abstract tropical cycle, $\varphi \in R(C)$ a bounded rational function on C and $((X, |X|, \{m_\sigma\}_{\sigma \in X}), \omega_X, \{M_\sigma\}_{\sigma \in X})$ a representative of C such that $|X| = |C|$ and for all $\sigma \in X$ the map $\varphi \circ m_\sigma^{-1} =: \varphi_\sigma$ is integer affine linear. Then*

$$\sum_{\{p\} \in X^{(0)}} \omega_\varphi(\{p\}) = 0,$$

i.e. $\varphi \cdot C$ is of degree zero.

Proof. By definition, for all $\{p\} \in X^{(0)}$ we have

$$\omega_\varphi(\{p\}) = \sum_{\substack{\sigma \in X^{(1)} \\ p \in \sigma}} \omega(\sigma) \varphi_\sigma(u_{\sigma/\{p\}}).$$

Note that if $\sigma \in X^{(1)}$ contains two different vertices, say $\partial_1\sigma$ and $\partial_2\sigma$, we have $u_{\sigma/\{\partial_1\sigma\}} = -u_{\sigma/\{\partial_2\sigma\}}$. If, otherwise, σ contains less than two vertices, $m_\sigma(\sigma)$ is a non-compact polyhedron and therefore φ can only be bounded if it is constant on σ . Together we get

$$\begin{aligned} \sum_{\{p\} \in X^{(0)}} \omega_\varphi(\{p\}) &= \sum_{\{p\} \in X^{(0)}} \sum_{\substack{\sigma \in X^{(1)} \\ p \in \sigma}} \omega(\sigma) \varphi_\sigma(u_{\sigma/\{p\}}) \\ &= \sum_{\substack{\sigma \in X^{(1)} \\ \exists! \partial\sigma \in \sigma}} \omega(\sigma) \varphi_\sigma(u_{\sigma/\{\partial\sigma\}}) \\ &\quad + \sum_{\substack{\sigma \in X^{(1)} \\ \exists! \partial_1\sigma, \partial_2\sigma \in \sigma}} \omega(\sigma) \varphi_\sigma(u_{\sigma/\{\partial_1\sigma\}}) + \omega(\sigma) \varphi_\sigma(u_{\sigma/\{\partial_2\sigma\}}) \\ &= \sum_{\substack{\sigma \in X^{(1)} \\ \exists! \partial\sigma \in \sigma}} \omega(\sigma) \cdot 0 \\ &\quad + \sum_{\substack{\sigma \in X^{(1)} \\ \exists! \partial_1\sigma, \partial_2\sigma \in \sigma}} \omega(\sigma) \underbrace{(\varphi_\sigma(u_{\sigma/\{\partial_1\sigma\}}) - \varphi_\sigma(u_{\sigma/\{\partial_2\sigma\}}))}_{=0} \\ &= 0. \end{aligned}$$

□

Remark 8.4. As a consequence, for any cycle $C \in Z_*(A)$ there is a well-defined morphism

$$\deg : A_0(C) \longrightarrow \mathbb{Z} : [\lambda_1 P_1 + \dots + \lambda_r P_r] \longmapsto \lambda_1 + \dots + \lambda_r.$$

For $D \in A_0(C)$ the number $\deg(D)$ is called the *degree* of D .

Moreover, by corollary 8.1 there is a well-defined map of top products

$$\text{Pic}(A)^d \longrightarrow \mathbb{Z} : ([\varphi_1], \dots, [\varphi_{\dim(C)}]) \longmapsto \deg([\varphi_1 \cdots \varphi_{\dim(C)} \cdot C]),$$

where A is our ambient cycle and d is the dimension of C . Of course, this map is of particular interest when dealing with enumerative questions.

Of course, our chosen rational equivalence $R(A) := \{[|A|, \varphi] \mid \varphi \text{ bounded}\}$ should also be compatible with pull-back and push-forward. However, in the push-forward case we face problems due to our definition of rational functions. Let us first state the positive result in the pull-back case.

Lemma 8.5 (Pull-back of rational equivalence). *Let C, D be tropical cycles and let $f : C \rightarrow D$ be a morphism between them. Then the pull-back map $\text{Div}(D) \rightarrow \text{Div}(C)$, $\varphi \mapsto f^*\varphi$ induces a well-defined map on the quotients $\text{Pic}(D) \rightarrow \text{Pic}(C)$, $[\varphi] \mapsto [f^*\varphi]$.*

Proof. We only have to show that for each element $(|D|, \psi) \in R(D)$ the pull-back Cartier divisor $f^*(|D|, \psi)$ lies in $R(C)$. But this follows from the trivial fact that the composition $\psi \circ f$ of a bounded function ψ and an arbitrary map f is again bounded. □

Remark 8.6 (Push-forward of rational equivalence). The corresponding statement for push-forwards is false! Let us again consider the elliptic curve C from Example 6.2. On this curve, the Weil divisor associated to the bounded rational function ψ illustrated in the picture below equals $\text{div}(\psi) = \alpha_1 + \alpha_2 - \alpha_3 - \alpha_4$.

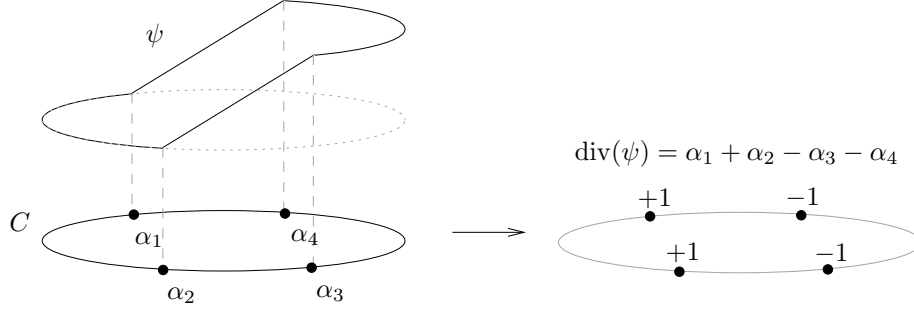

Let us now consider the cycle D obtained by identifying α_1 with α_3 and the canonical projection map $f : C \rightarrow D$.

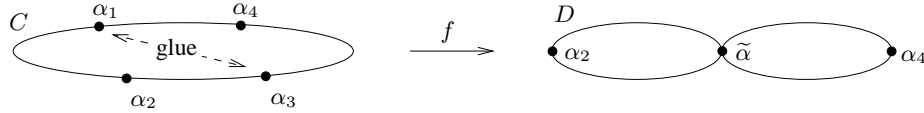

The push-forward of $\text{div}(\psi)$ under this morphism is $f_* \text{div}(\psi) = \alpha_2 - \alpha_4$. But this Weil divisor can obviously not be obtained by a rational function on D . This problem is due to our restrictive definition of rational functions (see remark 3.2). We are currently working on a refined version of the related definitions.

9. INTERSECTION OF CYCLES IN \mathbb{R}^n

So far we are only able to intersect Cartier divisors with cycles. Our aim in this section is now to define the intersection of two cycles with ambient cycle \mathbb{R}^n (with trivial structure maps). But first we need some preparations:

Definition 9.1. Let $((X, |X|, \{\varphi_\sigma\}), \omega_X, \{\Phi_\sigma\})$ and $((Y, |Y|, \{\psi_\tau\}), \omega_Y, \{\Psi_\tau\})$ be tropical polyhedral complexes. We denote by

$$(((X, |X|, \{\varphi_\sigma\}), \omega_X, \{\Phi_\sigma\}) \times ((Y, |Y|, \{\psi_\tau\}), \omega_Y, \{\Psi_\tau\}))$$

their *cartesian product*

$$(((X \times Y, |X| \times |Y|, \{\vartheta_{\sigma \times \tau}\}), \omega_{X \times Y}, \{\Theta_{\sigma \times \tau}\}),$$

where

$$\begin{aligned} X \times Y &:= \{\sigma \times \tau \mid \sigma \in X, \tau \in Y\}, \\ \vartheta_{\sigma \times \tau} &:= \varphi_\sigma \times \psi_\tau : \sigma \times \tau \longrightarrow \mathbb{R}^{n_\sigma} \times \mathbb{R}^{n_\tau}, \\ \omega_{X \times Y}(\sigma \times \tau) &:= \omega_X(\sigma) \cdot \omega_Y(\tau), \\ \Theta_{\sigma \times \tau} &:= \Phi_\sigma \times \Psi_\tau : S_\sigma^X \times S_\tau^Y \longrightarrow |F_\sigma^X| \times |F_\tau^Y|. \end{aligned}$$

Let \tilde{F}_σ^X and \tilde{F}_τ^Y be the entire fans associated with F_σ^X and F_τ^Y from above. Obviously, the product $\tilde{F}_\sigma^X \times \tilde{F}_\tau^Y := \{\alpha \times \beta \mid \alpha \in \tilde{F}_\sigma^X, \beta \in \tilde{F}_\tau^Y\}$ with weight function

$\omega_{\tilde{F}_\sigma^X \times \tilde{F}_\tau^Y}(\alpha \times \beta) := \omega_{\tilde{F}_\sigma^X}(\alpha) \cdot \omega_{\tilde{F}_\tau^Y}(\beta)$ is again a tropical fan and thus its intersection with $|F_\sigma^X| \times |F_\tau^Y|$ yields an open fan (cf. definition 5.3). Hence the cartesian product $((X \times Y, |X| \times |Y|, \{\vartheta_{\sigma \times \tau}\}), \omega_{X \times Y}, \{\Theta_{\sigma \times \tau}\})$ is again a tropical polyhedral complex.

If $C = [(X, \omega_X)]$ and $D = [(Y, \omega_Y)]$ are tropical cycles we define

$$C \times D := [(X, \omega_X) \times (Y, \omega_Y)]$$

for $(X, \omega_X) \times (Y, \omega_Y)$ as defined above. Note that $C \times D$ does not depend on the choice of the representatives X and Y .

Remark 9.2. We can express the diagonal in $\mathbb{R}^n \times \mathbb{R}^n$

$$[(\Delta, 1)] = [(\{(x, x) | x \in \mathbb{R}^n\}, 1)] \in Z_n(\mathbb{R}^n \times \mathbb{R}^n)$$

as a product of Cartier divisors, namely

$$[(\Delta, 1)] = \psi_1 \cdots \psi_n \cdot \mathbb{R}^n \times \mathbb{R}^n,$$

where $\psi_i = [\{\mathbb{R}^n, \max\{0, x_i - y_i\}\}] \in \text{Div}(\mathbb{R}^n \times \mathbb{R}^n)$, $i = 1, \dots, n$. We will use this ability to define the intersection product of any two cycles in \mathbb{R}^n .

Definition 9.3. Let $\pi : \mathbb{R}^n \times \mathbb{R}^n \rightarrow \mathbb{R}^n : (x, y) \mapsto x$. Then we define the intersection product of cycles in \mathbb{R}^n by

$$\begin{aligned} Z_{n-k}(\mathbb{R}^n) \times Z_{n-l}(\mathbb{R}^n) &\longrightarrow Z_{n-k-l}(\mathbb{R}^n) \\ (C, D) &\longmapsto C \cdot D := \pi_*(\Delta \cdot (C \times D)), \end{aligned}$$

where π_* denotes the push-forward as defined in 7.4 and $\Delta \cdot (C \times D) := \psi_1 \cdots \psi_n \cdot (C \times D)$ with ψ_1, \dots, ψ_n as defined in remark 9.2.

Having defined this intersection product of arbitrary cycles in \mathbb{R}^n we will prove now some basic properties. But as a start we need the following lemmas:

Lemma 9.4. Let $C \in Z_k(\mathbb{R}^n)$ be a cycle with representative (X, ω_X) and let ψ_1, \dots, ψ_n be the Cartier divisors defined in remark 9.2. Then (X_j, ω_{X_j}) with

$$\begin{aligned} X_j &:= \{(\mathbb{R}^n \times \sigma) \cap \{(x, y) \in \mathbb{R}^n \times \mathbb{R}^n | x_i = y_i \text{ for } i = j, \dots, n\} | \sigma \in X\}, \\ \omega_{X_j} &((\mathbb{R}^n \times \sigma) \cap \{(x, y) \in \mathbb{R}^n \times \mathbb{R}^n | x_i = y_i \text{ for } i = j, \dots, n\}) := \omega_X(\sigma) \end{aligned}$$

is a representative of $\psi_j \cdots \psi_n \cdot \mathbb{R}^n \times C$.

Proof. We use induction on j . For $j = n + 1$ there is nothing to show. Now let the above representative be correct for some $j + 1$. We have to show that X_j is a tropical polyhedral complex and that it represents $\psi_j \cdots \psi_n \cdot \mathbb{R}^n \times C$: Note that

$$\begin{aligned} &\dim((\mathbb{R}^n \times \sigma) \cap \{(x, y) \in \mathbb{R}^n \times \mathbb{R}^n | x_i = y_i \text{ for } i = j, \dots, n\}) \\ &< \dim((\mathbb{R}^n \times \sigma) \cap \{(x, y) \in \mathbb{R}^n \times \mathbb{R}^n | x_i = y_i \text{ for } i = j + 1, \dots, n\}) \end{aligned} \quad (*)$$

for all $\sigma \in X$. Hence X_j is a tropical polyhedral complex. Moreover note that

$$\tilde{X}_{j+1} := \{\sigma \cap \{x_j - y_j = 0\}, \sigma \cap \{x_j - y_j \leq 0\}, \sigma \cap \{x_j - y_j \geq 0\} | \sigma \in X_{j+1}\}$$

with weights induced by X_{j+1} is a refinement of X_{j+1} such that $\max\{0, x_j - y_j\}$ is linear on every face of \tilde{X}_{j+1} . By (*) there are exactly two types of faces of codimension one in \tilde{X}_{j+1} :

- (i) $(\mathbb{R}^n \times \sigma) \cap \{x_i - y_i = 0 \text{ for } i = j, \dots, n\}$ with $\sigma \in X$, $\text{codim}(\sigma) = 0$,

- (ii) $(\mathbb{R}^n \times \sigma) \cap \{x_i - y_i = 0 \text{ for } i = j + 1, \dots, n; x_j - y_j \leq 0\}$ or
 $(\mathbb{R}^n \times \sigma) \cap \{x_i - y_i = 0 \text{ for } i = j + 1, \dots, n; x_j - y_j \geq 0\}$ with $\sigma \in X$,
 $\text{codim}(\sigma) = 1$,

where the faces of the second type are not contained in $\{(x, y) \in \mathbb{R}^n \times \mathbb{R}^n | x_j = y_j\}$. Hence $\max\{0, x_j - y_j\}$ is linear on a neighborhood of every face of type (ii) and thus these faces get weight zero in $\max\{0, x_j - y_j\} \cdot \tilde{X}_{j+1}$. The faces of type (i) are weighted by $\omega_{X_{j+1}}((\mathbb{R}^n \times \sigma) \cap \{x_i - y_i = 0 \text{ for } i = j + 1, \dots, n\})$ in $\max\{0, x_j - y_j\} \cdot \tilde{X}_{j+1}$ since $x_1 - y_1, \dots, x_n - y_n$ are part of a lattice basis of $(\mathbb{Z}^n \times \mathbb{Z}^n)^\vee$. Thus $\max\{0, x_j - y_j\} \cdot \tilde{X}_{j+1} = X_j$ and X_j is a representative of $\psi_j \cdots \psi_n \cdot \mathbb{R}^n \times C$. \square

Corollary 9.5. *Let $C \in Z_k(\mathbb{R}^n)$ be a cycle. Then we have the equation:*

$$\mathbb{R}^n \cdot C = C.$$

Proof. Let (X, ω_X) be a representative of C , let $\pi : \mathbb{R}^n \times \mathbb{R}^n \rightarrow \mathbb{R}^n : (x, y) \mapsto x$ and let ψ_1, \dots, ψ_n be the Cartier divisors defined in remark 9.2. By lemma 9.4 we know that $X_1 = \{\{(x, x) | x \in \sigma\} | \sigma \in X\}$ with $\omega_{X_1}(\{(x, x) | x \in \sigma\}) = \omega_X(\sigma)$ is a representative of $\psi_1 \cdots \psi_n \cdot \mathbb{R}^n \times C$. Hence

$$\mathbb{R}^n \cdot C = \pi_*(\psi_1 \cdots \psi_n \cdot \mathbb{R}^n \times C) = [\pi_*(X_1, \omega_{X_1})] = [(X, \omega_X)] = C. \quad \square$$

Lemma 9.6. *Let $C \in Z_k(\mathbb{R}^n)$ and $D \in Z_l(\mathbb{R}^m)$ be abstract cycles, $\varphi \in \text{Div}(\mathbb{R}^n)$ a Cartier divisor and $\pi : \mathbb{R}^n \times \mathbb{R}^m \rightarrow \mathbb{R}^n : (x, y) \mapsto x$. Then:*

$$(\varphi \cdot C) \times D = \pi^* \varphi \cdot (C \times D).$$

Proof. We prove the statement for affine cycles C, D and an affine Cartier divisor φ . The general case then follows by applying the statement locally.

Choose arbitrary representatives Y of D and h of φ and choose a representative X of C such that h is linear on every face of X . This implies that $\pi^* h$ is linear on every face of $X \times Y$, too. In $X \times Y$ we have two types of faces of codimension one:

- (i) $\sigma \times \tau$ with $\sigma \in X, \tau \in Y, \text{codim}(\sigma) = 1, \text{codim}(\tau) = 0$,
(ii) $\sigma \times \tau$ with $\sigma \in X, \tau \in Y, \text{codim}(\sigma) = 0, \text{codim}(\tau) = 1$.

For the second type the adjacent facets are exactly all $\sigma \times \tilde{\tau}$ with $\tilde{\tau} > \tau$. We get $\omega_h(\sigma \times \tau) = 0$ in $h \cdot X \times Y$ as $\pi^* h$ is linear on $\sigma \times |Y|$. For the first type the adjacent facets are exactly all $\tilde{\sigma} \times \tau$ with $\tilde{\sigma} > \sigma$ and the weights can be calculated exactly like for $h \cdot X$. This finishes the proof. \square

Let C and D be cycles in \mathbb{R}^n . Assume that C can be expressed as a product of Cartier divisors, i.e. there are $\varphi_1, \dots, \varphi_r \in \text{Div}(\mathbb{R}^n)$ such that $C = \varphi_r \cdots \varphi_1 \cdot \mathbb{R}^n$. The obvious questions are now how $C \cdot D$ relates to $\varphi_r \cdots \varphi_1 \cdot D$ and whether $\varphi_r \cdots \varphi_1 \cdot D$ depends on the choice of the Cartier divisors φ_i . To answer this question we first prove a somewhat stronger statement:

Lemma 9.7. *Let $C \in Z_k(\mathbb{R}^n)$ and $D \in Z_l(\mathbb{R}^n)$ be cycles and $\varphi \in \text{Div}(\mathbb{R}^n)$ a Cartier divisor. Then we have the equality:*

$$(\varphi \cdot C) \cdot D = \varphi \cdot (C \cdot D).$$

Proof. Let $\pi : \mathbb{R}^n \times \mathbb{R}^n \rightarrow \mathbb{R}^n : (x, y) \mapsto x$ be like above. It holds:

$$\begin{aligned} (\varphi \cdot C) \cdot D &= \pi_*(\Delta \cdot (\varphi \cdot C) \times D) \\ &\stackrel{9.6}{=} \pi_*(\pi^* \varphi \cdot \Delta \cdot C \times D) \\ &\stackrel{7.7}{=} \varphi \cdot \pi_*(\Delta \cdot C \times D) \\ &= \varphi \cdot (C \cdot D). \end{aligned}$$

□

Corollary 9.8. *Let $C \in Z_k(\mathbb{R}^n)$ be a cycle such that there are Cartier divisors $\varphi_1, \dots, \varphi_r \in \text{Div}(\mathbb{R}^n)$ with $\varphi_r \cdots \varphi_1 \cdot \mathbb{R}^n = C$ and let $D \in Z_l(\mathbb{R}^n)$ be any cycle. Then*

$$\varphi_r \cdots \varphi_1 \cdot D = C \cdot D.$$

Proof. Applying lemma 9.7 and lemma 9.4 we obtain

$$C \cdot D = (\varphi_r \cdots \varphi_1 \cdot \mathbb{R}^n) \cdot D = \varphi_r \cdots \varphi_1 \cdot (\mathbb{R}^n \cdot D) = \varphi_r \cdots \varphi_1 \cdot D.$$

□

Remark 9.9. Note that corollary 9.8 in particular implies that our definition of the intersection product on \mathbb{R}^n (cf. 9.3) is independent of the choice of the Cartier divisors describing the diagonal Δ .

Theorem 9.10. *Let $C, C' \in Z_k(\mathbb{R}^n)$, $D \in Z_l(\mathbb{R}^n)$ and $E \in Z_m(\mathbb{R}^n)$ be cycles. Then the following equations hold:*

- (a) $C \cdot D = D \cdot C$,
- (b) $(C + C') \cdot D = C \cdot D + C' \cdot D$,
- (c) $(C \cdot D) \cdot E = C \cdot (D \cdot E)$.

Proof. (a): Let $\psi_1, \dots, \psi_n \in \text{Div}(\mathbb{R}^n \times \mathbb{R}^n)$ be like defined in remark 9.2. Note that for every $i \in \{1, \dots, n\}$ the maps $\max\{0, x_i - y_i\}$ and $\max\{0, y_i - x_i\}$ only differ by a globally linear map and hence define the same Cartier divisor. Thus we get

$$\pi_*(\psi_1 \cdots \psi_n \cdot C \times D) = \pi_*(\psi_1 \cdots \psi_n \cdot D \times C).$$

(b): Follows immediately by bilinearity of the intersection product

$$\text{Div}(\mathbb{R}^n \times \mathbb{R}^n) \times Z_p(\mathbb{R}^n \times \mathbb{R}^n) \xrightarrow{\cdot} Z_{p-1}(\mathbb{R}^n \times \mathbb{R}^n),$$

linearity of the push-forward and the fact that $(C + C') \times D = C \times D + C' \times D$.

(c): We will show that $\Delta \cdot C \times (\pi_*(\Delta \cdot D \times E)) = \Delta \cdot (\pi_*(\Delta \cdot C \times D) \times E)$:
Let $\pi^{12} : (\mathbb{R}^n)^3 \rightarrow (\mathbb{R}^n)^2 : (x, y, z) \mapsto (x, y)$, $\pi^{13} : (\mathbb{R}^n)^3 \rightarrow (\mathbb{R}^n)^2 : (x, y, z) \mapsto (x, z)$
and $\pi^{23} : (\mathbb{R}^n)^3 \rightarrow (\mathbb{R}^n)^2 : (x, y, z) \mapsto (y, z)$. An easy calculation shows that

$$\Delta \cdot C \times (\pi_*(\Delta \cdot D \times E)) = \Delta \cdot \pi_*^{12}(C \times (\Delta \cdot D \times E)) \quad (1)$$

and

$$\Delta \cdot (\pi_*(\Delta \cdot C \times D) \times E) = \Delta \cdot \pi_*^{13}((\Delta \cdot C \times D) \times E). \quad (2)$$

Now let ψ_1, \dots, ψ_n be the Cartier divisors defined in remark 9.2. We label these Cartier divisors with pairs of letters ψ_i^{xy} to point out the coordinates they are acting on. We obtain

$$\begin{aligned}
& \Delta \cdot C \times (\pi_*(\Delta \cdot D \times E)) \\
& \stackrel{(1)}{=} \Delta \cdot \pi_*^{12}(C \times (\Delta \cdot D \times E)) \\
& = \psi_1^{xy} \dots \psi_n^{xy} \cdot \pi_*^{12}(C \times (\psi_1^{yz} \dots \psi_n^{yz} \cdot D \times E)) \\
& \stackrel{7.7}{=} \pi_*^{12}((\pi^{12})^* \psi_1^{xy} \dots (\pi^{12})^* \psi_n^{xy} \cdot C \times (\psi_1^{yz} \dots \psi_n^{yz} \cdot D \times E)) \\
& \stackrel{9.6}{=} \pi_*^{12}((\pi^{23})^* \psi_1^{yz} \dots (\pi^{23})^* \psi_n^{yz} \cdot (\pi^{12})^* \psi_1^{xy} \dots (\pi^{12})^* \psi_n^{xy} \cdot C \times D \times E) \\
& \stackrel{9.8}{=} \pi_*^{13}((\pi^{12})^* \psi_1^{xy} \dots (\pi^{12})^* \psi_n^{xy} \cdot (\pi^{13})^* \psi_1^{xz} \dots (\pi^{13})^* \psi_n^{xz} \cdot C \times D \times E) \\
& \stackrel{9.6}{=} \pi_*^{13}((\pi^{13})^* \psi_1^{xz} \dots (\pi^{13})^* \psi_n^{xz} \cdot (\psi_1^{xy} \dots \psi_n^{xy} \cdot C \times D) \times E) \\
& \stackrel{7.7}{=} \psi_1^{xz} \dots \psi_n^{xz} \cdot \pi_*^{13}((\psi_1^{xy} \dots \psi_n^{xy} \cdot C \times D) \times E) \\
& = \Delta \cdot \pi_*^{13}((\Delta \cdot C \times D) \times E) \\
& \stackrel{(2)}{=} \Delta \cdot (\pi_*(\Delta \cdot C \times D) \times E).
\end{aligned}$$

This proves (d). \square

It remains to show that our intersection product is well-defined modulo rational equivalence. If this is the case the intersection product induced on $A_*(\mathbb{R}^n)$ clearly inherits the properties of the intersection product on $Z_*(\mathbb{R}^n)$ we have proven in this section.

Proposition 9.11. *The intersection product $Z_{n-k}(\mathbb{R}^n) \times Z_{n-l}(\mathbb{R}^n) \xrightarrow{\cdot} Z_{n-k-l}(\mathbb{R}^n)$ induces a well-defined and bilinear map*

$$A_{n-k}(\mathbb{R}^n) \times A_{n-l}(\mathbb{R}^n) \xrightarrow{\cdot} A_{n-k-l}(\mathbb{R}^n) : ([C], [D]) \mapsto [C] \cdot [D] := [C \cdot D].$$

Proof. Let $h \cdot C \in R_{n-k}$ (cf. section 8) and $D \in Z_{n-l}(\mathbb{R}^n)$. Using lemma 9.7 we can conclude that $(h \cdot C) \cdot D = h \cdot (C \cdot D) \in R_{n-k-l}$. \square

Our last step in this section is to prove a Bézout-style theorem for a special class of tropical cycles in \mathbb{R}^n called \mathbb{P}^n -generic cycles. But first we need some further definitions:

Definition 9.12. Let X be a tropical polyhedral complex in \mathbb{R}^n and let $v \in \mathbb{R}^n$. We denote by $X(v)$ the translation

$$X(v) := \{\sigma + v \mid \sigma \in X\}$$

of X along v . If $[X] = C \in Z_k(\mathbb{R}^n)$ then $C(v) := [X(v)]$. Note that the class $C(v)$ is independent of the representative X .

Definition 9.13. Let $C \in Z_k(\mathbb{R}^n)$ be a tropical cycle and let L_k^n be the tropical fan defined in example 3.9. Then we define the *degree of C* to be the number

$$\deg(C) := \deg(C \cdot [L_{\text{codim } X}^n]),$$

where the second map $\deg : Z_0(\mathbb{R}^n) \rightarrow \mathbb{Z} : \lambda_1 P_1 + \dots + \lambda_r P_r \mapsto \lambda_1 + \dots + \lambda_r$ is the usual degree map. Then the map $\deg : Z_k(\mathbb{R}^n) \rightarrow \mathbb{Z}$ is obviously linear by definition. Moreover, we define the degree of $[C] \in A_k(\mathbb{R}^n)$ to be $\deg([C]) := \deg(C)$. Note that $\deg([C])$ is well-defined by remark 8.4.

Lemma 9.14. *Let $C \in Z_k(\mathbb{R}^n)$ and $D \in Z_{n-k}(\mathbb{R}^n)$ be two tropical cycles of complementary dimensions. Then*

$$\deg(C \cdot D) = \deg(C(v_1) \cdot D(v_2))$$

for all vectors $v_1, v_2 \in \mathbb{R}^n$. In particular $\deg(C) = \deg(C(v))$ for all $v \in \mathbb{R}^n$.

Proof. Let $\pi : \mathbb{R}^n \times \mathbb{R}^n \rightarrow \mathbb{R}^n : (x, y) \mapsto x$ be the projection map as above and for $u = (u_1, \dots, u_n) \in \mathbb{R}^n$ let

$$\Delta(u) \cdot (C \times D) := \psi_1(u_1) \cdots \psi_n(u_n) \cdot (C \times D)$$

with $\psi_i(u_i) := [\{(\mathbb{R}^n, \max\{0, x_i - y_i + u_i\})\}] \in \text{Div}(\mathbb{R}^n \times \mathbb{R}^n)$ be the intersection with the translated diagonal (cf. definition 9.3). Note that the rational function $\max\{0, x_i - y_i\} - \max\{0, x_i - y_i + u_i\}$ is bounded and that hence $[\psi_i] = [\psi_i(u_i)] \in \text{Pic}(\mathbb{R}^n \times \mathbb{R}^n)$ for all i . It follows that

$$[\Delta \cdot (C \times D)] = [\Delta(u) \cdot (C \times D)] \in A_0(\mathbb{R}^n \times \mathbb{R}^n)$$

and thus we get

$$\begin{aligned} \deg(C \cdot D) &= \deg(\pi_*(\Delta \cdot (C \times D))) \\ &= \deg(\Delta \cdot (C \times D)) \\ &\stackrel{8.4}{=} \deg(\Delta(v_1 - v_2) \cdot (C \times D)) \\ &= \deg(\Delta \cdot (C(v_1) \times D(v_2))) \\ &= \deg(\pi_*(\Delta \cdot (C(v_1) \times D(v_2)))) \\ &= \deg(C(v_1) \cdot D(v_2)). \end{aligned}$$

□

Definition 9.15 (\mathbb{P}^n -generic cycles). Let $C \in Z_k(\mathbb{R}^n)$ be a tropical cycle. C is called \mathbb{P}^n -generic if for one (and thus for every) representative X of C holds: For every face $\sigma \in X^{(k)}$ there exists a polytope $P_\sigma \subseteq \mathbb{R}^n$ of some dimension $r \in \{0, \dots, k\}$ and a cone $\tilde{\sigma} \in (L_k^n)^{(k-r)}$ such that $\sigma \subseteq P_\sigma + \tilde{\sigma}$.

Theorem 9.16 (Bézout's theorem). *Let $C \in Z_k(\mathbb{R}^n)$ and $D \in Z_{n-k}(\mathbb{R}^n)$ be two tropical cycles of complementary dimensions. Moreover, assume that C and D are \mathbb{P}^n -generic. Then:*

$$\deg(C \cdot D) = \deg(C) \cdot \deg(D).$$

Proof. Let (X, ω_X) be a representative of C and (Y, ω_Y) be a representative of D . Moving X along a (generic) direction vector $a = (a_1, \dots, a_n) \in \mathbb{R}_{\geq 0}^k \times \mathbb{R}_{\leq 0}^{n-k}$ we can reach that $|X(a)|$ and $|Y|$ intersect in points in the interior of maximal faces only, namely $|X(a)| \cap |Y| = \{P_{ij} \mid i = 1, \dots, r; j = 1, \dots, s\}$ with $P_{ij} = \sigma_i \cap \sigma'_j$ for facets (we use the notation introduced in example 3.9 for the cones of L_k^n here)

- $\sigma_i \in X(a)^{(k)}$ with $\sigma_i \subseteq \sigma_{\{1, \dots, k\}} + u_i \in L_k^n(u_i)$ and
- $\sigma'_j \in Y^{(n-k)}$ with $\sigma'_j \subseteq \sigma_{\{k+1, \dots, n\}} + v_j \in L_{n-k}^n(v_j)$.

Hence we can conclude that $X(a) \cdot Y = \sum_{i=1}^r \sum_{j=1}^s \omega_X(\sigma_i) \omega_Y(\sigma'_j) P_{ij}$ and thus by lemma 9.14

$$\deg(X \cdot Y) = \deg(X(a) \cdot Y) = \sum_{i=1}^r \sum_{j=1}^s \omega_X(\sigma_i) \omega_Y(\sigma'_j).$$

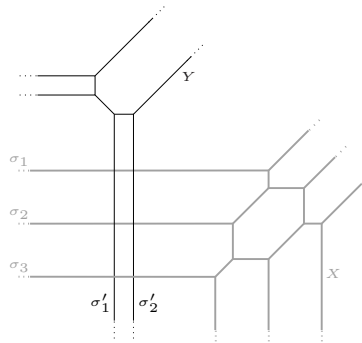

The intersection of $X(a)$ and Y as described in 9.16.

Moreover we can deduce that $|X(a)| \cap |L_{n-k}^n(v_1)| = \{P_{11}, \dots, P_{r1}\}$. Hence $X(a) \cdot L_{n-k}^n(v_1) = \sum_{i=1}^r \omega_X(\sigma_i) P_{i1}$ and again by lemma 9.14

$$\deg(X) = \deg(X(a) \cdot L_{n-k}^n(v_1)) = \sum_{i=1}^r \omega_X(\sigma_i).$$

Analogously we obtain

$$\deg(Y) = \deg(Y \cdot L_k^n(u_1)) = \sum_{j=1}^s \omega_Y(\sigma'_j).$$

Thus the claim follows. \square

REFERENCES

- [FS] W. Fulton, B. Sturmfels, *Intersection Theory on Toric Varieties*, Topology, Volume 36, Number 2, March 1997, pp. 335–353(19).
- [GKM] A. Gathmann, M.Kerber and H. Markwig, *Tropical fans and the moduli spaces of tropical curves*, Compositio Mathematica (to appear), preprint math.AG/0708.2268.
- [GM] A. Gathmann, H. Markwig, *Kontsevich's formula and the WDVV equations in tropical geometry*, Advances in Mathematics, Volume 217, Issue 2, January 2008, pp. 537–560(24).
- [K] E. Katz, *A Tropical Toolkit*, preprint math.AG/0610878.
- [KM] M.Kerber, H. Markwig, *Counting tropical elliptic plane curves with fixed j-invariant*, Commentarii Mathematici Helvetici (to appear), preprint math.AG/0608472.
- [M] G. Mikhalkin, *Tropical Geometry and its applications*, Proceedings of the ICM, Madrid, Spain (2006), 827–852(26).
- [RGST] J. Richter-Gebert, B. Sturmfels and T. Theobald, *First steps in tropical geometry*, Idempotent Mathematics and Mathematical Physics (G.L. Litvinov and V.P. Maslov, eds.), Proceedings Vienna 2003, American Mathematical Society, Contemp. Math., (377), 2005.
- [ST] B. Sturmfels and J. Tevelev, *Elimination theory for tropical varieties*, Mathematical Research Letters, Volume 15, Number 3, March 2008, pp. 543–562(20).

LARS ALLERMANN, FACHBEREICH MATHEMATIK, TU KAISERSLAUTERN, POSTFACH 3049, 67653 KAISERSLAUTERN, GERMANY

E-mail address: allerman@mathematik.uni-kl.de

JOHANNES RAU, FACHBEREICH MATHEMATIK, TU KAISERSLAUTERN, POSTFACH 3049, 67653 KAISERSLAUTERN, GERMANY

E-mail address: jrau@mathematik.uni-kl.de